

4

3

2

1

- 1.0 GENERAL NOTES
 - 1.1 ALL METRIC DIMENSIONS ARE IN BRACKETS [X.X]
 - 1.2 FOR PATENT INFO: <https://www.adwpat.com>
- 2.0 DESIGN NOTES
 - 2.1 ALLOWS MC-RM3060-3 TO INCREASE TO 70" OD.
- 3.0 MANUFACTURING/SPECIAL REQUIREMENTS
 - 3.1 TIGHTEN ALL BOLTS 3/8" OR LARGER SECURING FLAT PLATES SNUG TIGHT.
 - 3.2 SNUG TIGHT IS DEFINED AS THE CONDITION OBTAINED WITH A FEW IMPACTS OF AN IMPACT WRENCH OR THE FULL EFFORT OF AN INSTALLER USING AN ORDINARY SPUD WRENCH TO BRING THE CONNECTED LAYERS (PLIES) OF STEEL INTO FULL CONTACT.
 - 3.3 FOR BOLTS IN A PATTERN, TIGHTEN IN A CRISS-CROSS OR STAR SEQUENCE, INCREASING TORQUE IN GRADUAL STEPS UNTIL SNUG TIGHT.
- 4.0 TEST
- 5.0 PACKAGING
 - 5.1 PACKAGING SHALL MEET ANDREW REQUIREMENTS PER DOCUMENT IS-PL-3005
 - 5.2 PRINTED DOCUMENT TO BE PLACED INSIDE POLYBAG AND THEN IN SHIPPING CONTAINER
 - 5.3 EXTRA HARDWARE MAY BE SUPPLIED, BAGGED AND SHIPPED

REV.	DESCRIPTION	DATE	BY
A	INITIAL RELEASE	MSM 19OCT16	8000016793
B	UPDATED DRAWING FORMAT	NSUN 01DEC25	BA1025 50106034AMO

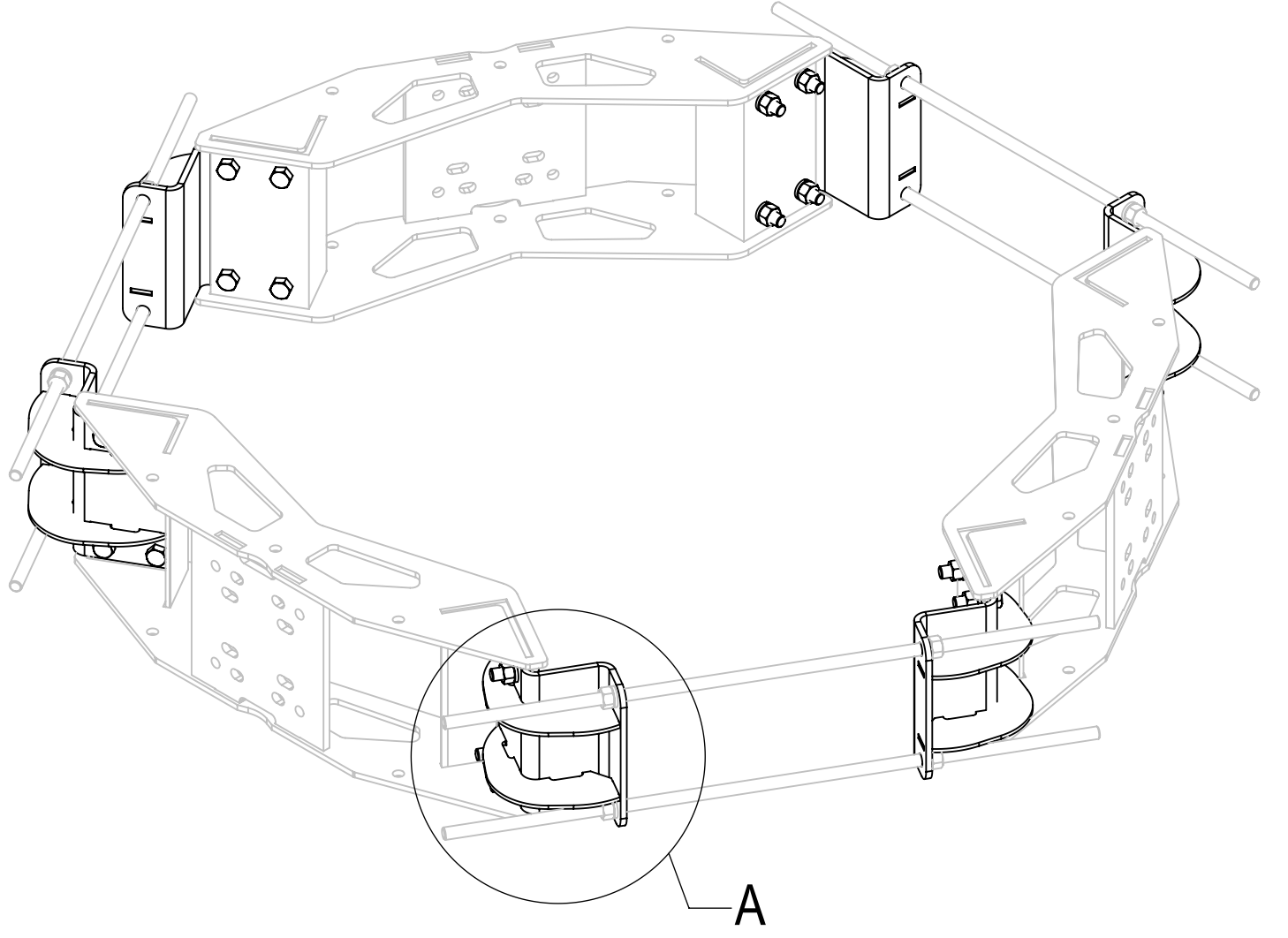
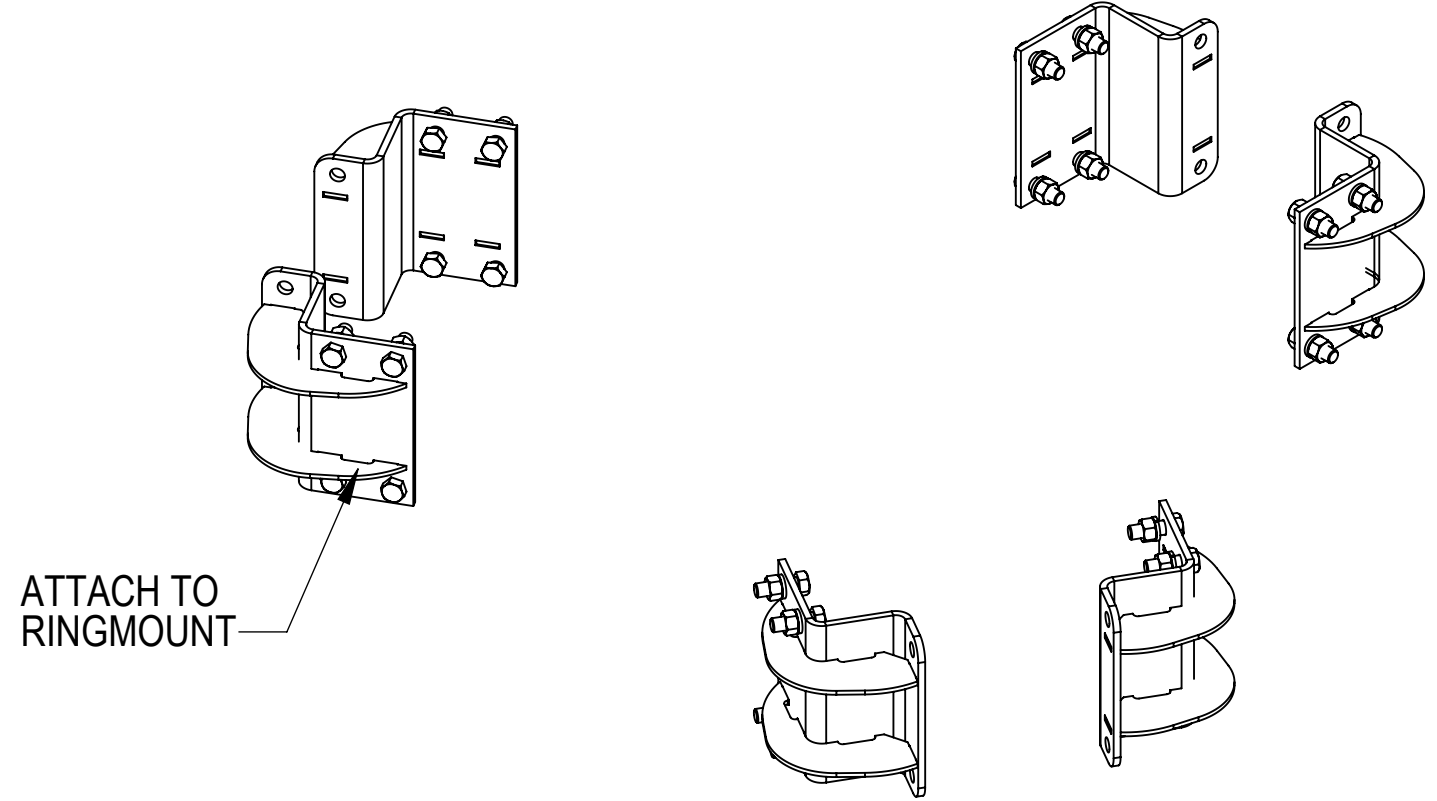

SHOWN WITH MC-RM3060-3

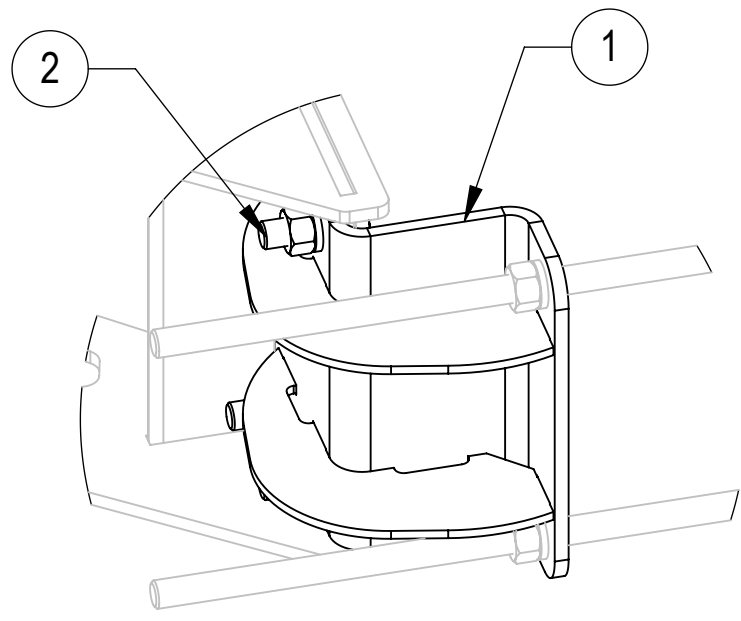

DETAIL A
SCALE 1 : 5

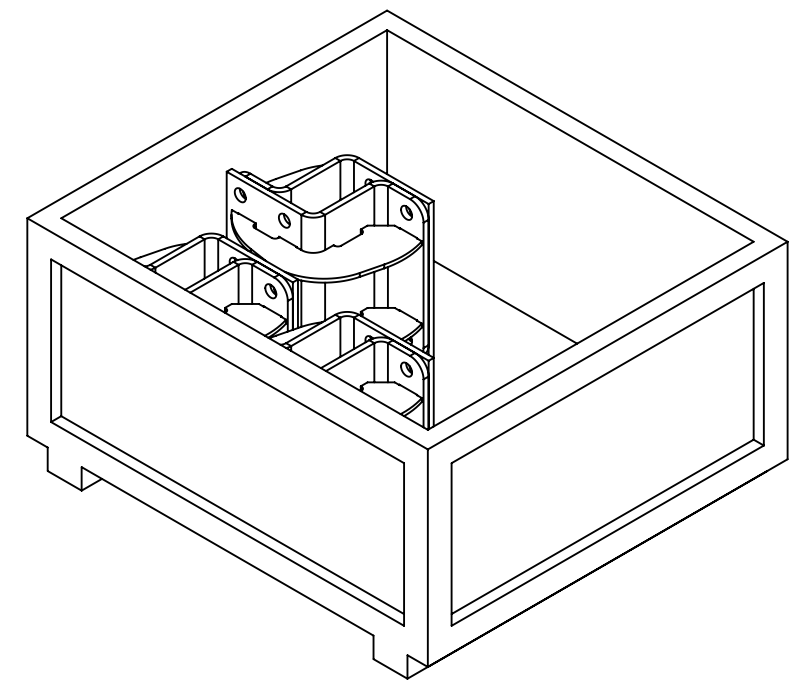

PACKING

COMPONENT PART NUMBERS PROVIDED FOR ASSEMBLY PURPOSES;
INDIVIDUAL COMPONENTS MAY BE SHIPPED AS PARTS WITHIN AN INCLUDED KIT.

ITEM	PART NO.	DESCRIPTION	QTY.	WEIGHT	NOTE NO.
1	MTC392401	WELDMENT EXTENSION BRACKET	6	17.91 LBS	
2	GB-0622A	3/4" X 2-1/4" GALV BOLT KIT A325	24	0.44 LBS	

DENSITY	122.41	lbs/in ³
MASS	434.38	lbs
VOLUME	2946.70	in ³
SURFACE AREA		in ²
HEIGHT		
LENGTH		
WIDTH		

Confidential

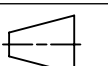

ANDREW® an Amphenol company

TOLERANCES		SAP MATERIAL MASTER	
0 PLACE X[X] ± 0.25[6.3]	2 PLACE .XX[X] ± 0.06[1.5]	MTC3924	
1 PLACE .X[X] ± 0.12[3.0]	ANGLES ± 2°		
FINISH		MATERIAL	
UNLESS OTHERWISE SPECIFIED DIMENSIONS ARE IN INCHES INTERPRET PER ANSI Y 14.5M-1994	NAME	DATE	TITLE
	CE MSM	19OCT16	RINGMOUNT EXTENSION KIT
	RW NSUN	12/01/2025	
	AD YMENG	12/04/2025	SCALE
	RE YMENG	12/04/2025	DOCUMENT NO.
ECN 50106034AMO		MTC3924	
SIZE	Auth Group	INSL	MODEL
C	 	VERSION	STATUS
		01	RE
		REVISION	VERSION
		B	01
		STATUS	REVISION
		RE	B
			SHEET
			1 OF 1

4

3

2

1