

# CTX61742T-DS-43 | E14F11P27



Twin Triplexer, 612-960/1695-2700/3300- 4200 MHz, 4.3-10 connectors, DC Sense

- New Combining Solution to introduce 5G, 3.5GHz band
- BTS-to-feeder and feeder-to-antenna application
- New 4.3-10 connectors for improved PIM performance and size reduction
- Automatic dc switching with dc sense
- Suitable for space limited applications like Metro Cell, Lamp Pole, Concealment Solution and Macro Site
- Ideal for small cell applications

## Product Classification

**Product Type** Triplexer

## General Specifications

**Color** Gray

**Common Port Label** COMM

**Modularity** 2-Twin

**Mounting** Pole | Wall

**Mounting Pipe Hardware** Band clamps (2)

**RF Connector Interface** 4.3-10 Female

**RF Connector Interface Body Style** Long neck

## Dimensions

**Height** 276 mm | 10.866 in

**Width** 146.5 mm | 5.768 in

**Depth** 64 mm | 2.52 in

**Ground Screw Diameter** 5 mm | 0.197 in

**Mounting Pipe Diameter Range** 43–122 mm

## Outline Drawing

# CTX61742T-DS-43 | E14F11P27

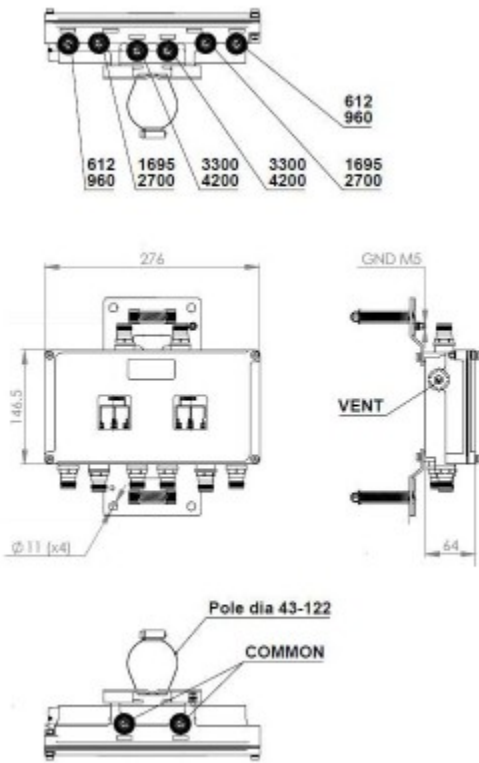

## Electrical Specifications

<b>Impedance</b>	50 ohm
<b>License Band, Band Pass</b>	APT 700   AWS 1700   CEL 850   CEL 900   DCS 1800   EDD 800   IMT 2100   IMT 2600   LMR 750   LMR 800   LMR 900   PCS 1900   TDD 3500   USA 600   USA 700   USA 750   WCS 2300

## Electrical Specifications, dc Power/Alarm

<b>dc/AISG Pass-through Method</b>	Auto sensing
<b>dc/AISG Pass-through Path</b>	Auto sensing circuitry detects dc/AISG signal presence and selects path
<b>dc/AISG Pass-through, combiner</b>	dc Smart Bypass
<b>dc/AISG Pass-through, demultiplexer</b>	dc Smart Bypass
<b>Lightning Surge Current</b>	5 kA
<b>Lightning Surge Current Waveform</b>	8/20 waveform
<b>Voltage</b>	7-30 Vdc

## Electrical Specifications

<b>Sub-module</b>	1   2	1   2	1   2
-------------------	-------	-------	-------

# CTX61742T-DS-43 | E14F11P27

<b>Branch</b>	1	2	3
<b>Port Designation</b>	617-960	1695-2700	3300-4200
<b>License Band</b>	USA 700, Band Pass USA 750, Band Pass USA 600, Band Pass CEL 850, Band Pass CEL 900, Band Pass	PCS 1900, Band Pass WCS 2300, Band Pass AWS 1700, Band Pass TDD 2300, Band Pass TDD 2600, Band Pass DCS 1800, Band Pass IMT 2100, Band Pass IMT 2600, Band Pass	TDD 3500, Band Pass

## Electrical Specifications, Band Pass

Frequency Range, MHz	617-960	1695-2700	3300-4200
<b>Insertion Loss, typical, dB</b>	0.15	0.2	0.25
<b>Total Group Delay, maximum, ns</b>	10	10	10
<b>Return Loss, typical, dB</b>	20	20	20
<b>Isolation, minimum, dB</b>	40 @ 1695-2700 50 @ 3300-4200	50 @ 612-960 50 @ 3300-4200	50 @ 612-960 40 @ 1695-2700
<b>Input Power, RMS, maximum, W</b>	140	140	80
<b>Input Power, PEP, maximum, W</b>	1600	1600	1600
<b>3rd Order PIM, maximum, dBc</b>	-161	-161	-155
<b>3rd Order PIM Test Method</b>	2 x 20 W CW tones	2 x 20 W CW tones	2 x 20 W CW tones

## Block Diagram

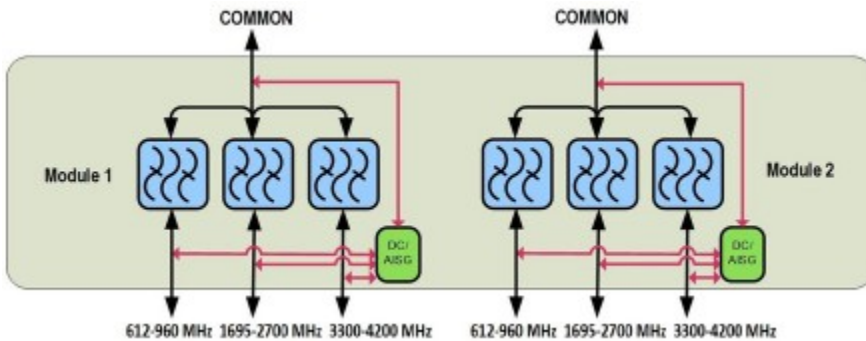

## Logic Table

# CTX61742T-DS-43 | E14F11P27

**COMBINER mode:** One of three Ports (1-3) is selected to the COMMON port

MODE	COMMON	Port 1695-2700	Port 3300-4200	Port 612-960	COMMON	Port 1695-2700	Port 3300-4200	Port 612-960
	Input Voltage				Selected Port			
Combiner	<7V	<7V	<7V	>7V	ON	OFF	OFF	ON
	<7V	<7V	>7V	<7V	ON	OFF	ON	OFF
	<7V	>7V	<7V	<7V	ON	ON	OFF	OFF
	<7V	<7V	>7V	>7V	ON	OFF	OFF	ON
	<7V	>7V	<7V	>7V	ON	ON	OFF	OFF
	<7V	>7V	>7V	<7V	ON	ON	OFF	OFF
	<7V	>7V	>7V	>7V	ON	ON	OFF	OFF

**COMBINER mode priority table**

Port 1695-2700 (highest), Port 612-960, Port 3300-4200 (lowest).

Port 1695-2700	Port 3300-4200	Port 612-960	COMMON
DC Input Voltage			Selected Port
any valid DC	any valid DC or <7V	any valid DC or <7V	Port 1695-2700
<7V	any valid DC or <7V	any valid DC	Port 612-960
<7V	any valid DC	<7V	Port 3300-4200
<7V	<7V	<7V	NONE

Note: Valid DC input voltage range is 7-30V

**SPLITTER mode:** COMMON port is split to Ports (1-3) with valid impedance

MODE	COMMON	Port 1695-2700	Port 3300-4200	Port 612-960	COMMON	Port 1695-2700	Port 3300-4200	Port 612-960
	Input Voltage				Selected Port			
Splitter	>7V	short	short	open/load	ON	OFF	OFF	ON
	>7V	short	open/load	short	ON	OFF	ON	OFF
	>7V	open/load	short	short	ON	ON	OFF	OFF
	>7V	short	open/load	open/load	ON	OFF	ON	ON
	>7V	open/load	short	open/load	ON	ON	OFF	ON
	>7V	open/load	open/load	short	ON	ON	ON	OFF
	>7V	open/load	open/load	open/load	ON	ON	ON	ON

**FAULT/OFF mode**

MODE	COMMON	Port 1695-2700	Port 3300-4200	Port 612-960	COMMON	Port 1695-2700	Port 3300-4200	Port 612-960
	Input Voltage				Selected Port			
Fault	>7V	>7V (any port)			OFF	OFF	OFF	OFF
OFF	<7V	<7V	<7V	<7V	OFF	OFF	OFF	OFF

## Environmental Specifications

<b>Operating Temperature</b>	-40 °C to +65 °C (-40 °F to +149 °F)
<b>Relative Humidity</b>	Up to 100%
<b>Corrosion Test Method</b>	IEC 60068-2-11, 30 days
<b>Ingress Protection Test Method</b>	IEC 60529:2001, IP67

# CTX61742T-DS-43 | E14F11P27

---

## Packaging and Weights

<b>Included</b>	Mounting hardware
<b>Volume</b>	2.6 L
<b>Weight, with mounting hardware</b>	4.1 kg   9.039 lb
<b>Weight, without mounting hardware</b>	6.3 kg   13.889 lb