

F1A-PNMNM-3M



FSJ1-50A SureFlex® Jumper with interface types N Male and N Male, 3 m

Product Classification

Product Type	SureFlex® standard
Product Brand	HELIAX® SureFlex®
Product Series	FSJ1-50A

General Specifications

Body Style, Connector A	Straight
Body Style, Connector B	Straight
Interface, Connector A	N Male
Interface, Connector B	N Male
Interface Coupling Nut Flat, Connector A	18 mm 0.709 in
Interface Coupling Nut Flat, Connector B	18 mm 0.709 in
Specification Sheet Revision Level	A

Dimensions

Length	3 m 9.843 ft
Nominal Size	1/4 in

VSWR/Return Loss

Frequency Band	VSWR	Return Loss (dB)
700–3000 MHz	1.222	20

Jumper Assembly Sample Label

F1A-PNMNM-3M



Environmental Specifications

Immersion Test Method

Meets IEC 60529:2001, IP68 in mated condition

Regulatory Compliance/Certifications

Agency

Classification

CHINA-ROHS	Below maximum concentration value
ISO 9001:2015	Designed, manufactured and/or distributed under this quality management system
REACH-SVHC	Compliant as per SVHC revision on www.andrew.com/ProductCompliance
ROHS	Compliant
UK-ROHS	Compliant



Included Products

F1TNM-LS	- Type N Male for 1/4 in foam and air coaxial cable, factory attached
FSJ1-50A	- FSJ1-50A, HELIAX® Superflexible Low Density Foam Coaxial Cable, corrugated copper, 1/4 in, black PE jacket

F1TNM-LS



Type N Male for 1/4 in foam and air coaxial cable, factory attached

Product Classification

Product Type	Wireless and radiating connector
Product Brand	HELIAX® SureFlex®

General Specifications

Body Style	Straight
Inner Contact Attachment Method	Solder
Inner Contact Plating	Silver
Interface	N Male
Outer Contact Attachment Method	Solder
Outer Contact Plating	Trimetal
Pressurizable	No

Dimensions

Length	26.67 mm 1.05 in
Diameter	20.32 mm 0.8 in
Nominal Size	1/4 in

F1TNM-LS

Outline Drawing

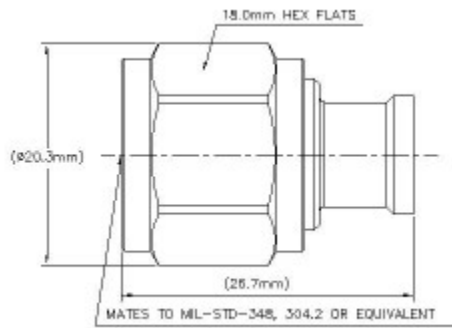

Electrical Specifications

3rd Order IMD at Frequency	-110 dBm @ 910 MHz
Insertion Loss Coefficient, typical	0.05
Average Power at Frequency	0.4 kW @ 900 MHz
Cable Impedance	50 ohm
Connector Impedance	50 ohm
dc Test Voltage	1600 V
Inner Contact Resistance, maximum	1 mOhm
Insulation Resistance, minimum	5000 MOhm
Operating Frequency Band	0 – 6000 MHz
Outer Contact Resistance, maximum	0.25 mOhm
Peak Power, maximum	6.4 kW
RF Operating Voltage, maximum (vrms)	565 V
Shielding Effectiveness	-110 dB

VSWR/Return Loss

Frequency Band	VSWR	Return Loss (dB)
0–960 MHz	1.036	35.05
1710–2200 MHz	1.046	32.96
2200–2700 MHz	1.065	30.04
2700–3000 MHz	1.065	30.04
3000–6000 MHz	1.152	23.02

Mechanical Specifications

F1TNM-LS

Connector Retention Tensile Force	667.23 N 150 lbf
Connector Retention Torque	1.1 N-m 9.736 in lb
Coupling Nut Proof Torque	1.7 N-m 15.046 in lb
Coupling Nut Proof Torque Method	IEC 61169-16:9.3.11
Coupling Nut Retention Force	445 N 100.04 lbf
Coupling Nut Retention Force Method	IEC 61169-15:9.3.11
Insertion Force	27.98 N 6.29 lbf
Insertion Force Method	IEC 61169-15:9.3.5
Interface Durability	500 cycles
Interface Durability Method	IEC 61169-4:17
Mechanical Shock Test Method	IEC 60068-2-27

Environmental Specifications

Operating Temperature	-55 °C to +85 °C (-67 °F to +185 °F)
Storage Temperature	-65 °C to +125 °C (-85 °F to +257 °F)
Attenuation, Ambient Temperature	20 °C 68 °F
Average Power, Ambient Temperature	40 °C 104 °F
Average Power, Inner Conductor Temperature	100 °C 212 °F
Corrosion Test Method	IEC 60068-2-11
Immersion Depth	1 m
Immersion Test Mating	Mated
Immersion Test Method	IEC 60529:2001, IP68
Moisture Resistance Test Method	IEC 60068-2-3
Thermal Shock Test Method	IEC 60068-2-14
Vibration Test Method	IEC 60068-2-6

Packaging and Weights

Weight, net	20.65 g 0.046 lb
--------------------	--------------------

Regulatory Compliance/Certifications

Agency	Classification
CHINA-ROHS	Below maximum concentration value
REACH-SVHC	Compliant as per SVHC revision on www.andrew.com/ProductCompliance

F1TNM-LS

ROHS Compliant

UK-ROHS Compliant



* Footnotes

Insertion Loss Coefficient, typical $0.05\sqrt{\text{freq (GHz)}}$ (not applicable for elliptical waveguide)

Immersion Depth Immersion at specified depth for 24 hours

FSJ1-50A



FSJ1-50A, HELIAX® Superflexible Low Density Foam Coaxial Cable, corrugated copper, 1/4 in, black PE jacket

Product Classification

Product Type	Coaxial wireless cable
Product Brand	HELIAX® SureFlex®
Product Series	FSJ1-50A MLOC

General Specifications

Product Number	887009902/00 SZ887009902/00
Flexibility	Superflexible
Jacket Color	Black
Performance Note	Attenuation values typical, guaranteed within 5%

Dimensions

Diameter Over Dielectric	4.826 mm 0.19 in
Diameter Over Jacket	7.366 mm 0.29 in
Inner Conductor OD	1.905 mm 0.075 in
Outer Conductor OD	6.35 mm 0.25 in
Nominal Size	1/4 in

Electrical Specifications

Cable Impedance	50 ohm ±1 ohm
Capacitance	79.4 pF/m 24.201 pF/ft
dc Resistance, Inner Conductor	9.843 ohms/km 3 ohms/kft
dc Resistance, Outer Conductor	7.216 ohms/km 2.199 ohms/kft
dc Test Voltage	1600 V
Inductance	0.2 µH/m 0.061 µH/ft
Insulation Resistance	100000 MOhms-km
Jacket Spark Test Voltage (rms)	5000 V
Operating Frequency Band	1 – 18000 MHz

FSJ1-50A

Peak Power 6.4 kW

Velocity 82 %

Attenuation

Frequency (MHz)	Attenuation (dB/100 m)	Attenuation (dB/100 ft)	Average Power (kW)
1.0	0.577	0.176	6.4
1.5	0.707	0.215	6.4
2.0	0.816	0.249	6.4
10.0	1.833	0.559	3.99
20.0	2.6	0.792	2.81
30.0	3.192	0.973	2.29
50.0	4.136	1.261	1.77
85.0	5.419	1.652	1.35
88.0	5.516	1.681	1.33
100.0	5.889	1.795	1.24
108.0	6.125	1.867	1.19
150.0	7.25	2.21	1.01
174.0	7.825	2.385	0.93
200.0	8.408	2.563	0.87
204.0	8.495	2.589	0.86
300.0	10.373	3.162	0.71
400.0	12.051	3.673	0.61
450.0	12.817	3.906	0.57
460.0	12.965	3.952	0.56
500.0	13.545	4.128	0.54
512.0	13.715	4.18	0.53
600.0	14.909	4.544	0.49
700.0	16.175	4.93	0.45
800.0	17.362	5.292	0.42
824.0	17.637	5.376	0.41
894.0	18.42	5.614	0.4
960.0	19.134	5.832	0.38
1000.0	19.556	5.96	0.37
1218.0	21.738	6.626	0.34
1250.0	22.044	6.719	0.33

FSJ1-50A

1500.0	24.326	7.414	0.3
1700.0	26.038	7.936	0.28
1794.0	26.813	8.172	0.27
1800.0	26.862	8.187	0.27
2000.0	28.455	8.673	0.26
2100.0	29.227	8.908	0.25
2200.0	29.984	9.139	0.24
2300.0	30.727	9.365	0.24
2500.0	32.174	9.806	0.23
2700.0	33.576	10.233	0.22
3000.0	35.602	10.851	0.21
3400.0	38.183	11.638	0.19
3600.0	39.428	12.017	0.19
3700.0	40.041	12.204	0.18
3800.0	40.647	12.389	0.18
3900.0	41.247	12.571	0.18
4000.0	41.841	12.753	0.17
4100.0	42.429	12.932	0.17
4200.0	43.012	13.11	0.17
4300.0	43.59	13.286	0.17
4400.0	44.163	13.46	0.17
4500.0	44.73	13.633	0.16
4600.0	45.293	13.805	0.16
4700.0	45.852	13.975	0.16
4800.0	46.405	14.144	0.16
4900.0	46.955	14.311	0.16
5000.0	47.5	14.477	0.15
6000.0	52.747	16.077	0.14
8000.0	62.37	19.01	0.12
8800.0	65.974	20.108	0.11
10000.0	71.173	21.693	0.1
12000.0	79.393	24.198	0.09
14000.0	87.172	26.569	0.08
15800.0	93.872	28.611	0.08
16000.0	94.601	28.833	0.08

FSJ1-50A

18000.0

101.745

31.01

0.07

Material Specifications

Dielectric Material	Foam PE
Jacket Material	PE
Inner Conductor Material	Copper-clad aluminum wire
Outer Conductor Material	Corrugated copper

Mechanical Specifications

Minimum Bend Radius, multiple Bends	25.4 mm 1 in
Minimum Bend Radius, single Bend	25.4 mm 1 in
Number of Bends, minimum	15
Number of Bends, typical	20
Tensile Strength	68 kg 149.914 lb
Bending Moment	0.7 N-m 6.196 in lb
Flat Plate Crush Strength	1.8 kg/mm 100.795 lb/in

Environmental Specifications

Installation temperature	-40 °C to +60 °C (-40 °F to +140 °F)
Operating Temperature	-55 °C to +85 °C (-67 °F to +185 °F)
Storage Temperature	-70 °C to +85 °C (-94 °F to +185 °F)
Attenuation, Ambient Temperature	68 °F 20 °C
Average Power, Ambient Temperature	104 °F 40 °C
Average Power, Inner Conductor Temperature	212 °F 100 °C

Packaging and Weights

Cable weight	0.07 kg/m 0.047 lb/ft
---------------------	-------------------------

Regulatory Compliance/Certifications

Agency	Classification
CHINA-ROHS	Below maximum concentration value
ISO 9001:2015	Designed, manufactured and/or distributed under this quality management system
REACH-SVHC	Compliant as per SVHC revision on www.andrew.com/ProductCompliance
ROHS	Compliant
UK-ROHS	Compliant

FSJ1-50A

UL/ETL Certification

Compliant

