

1.0 GENERAL NOTES

- 1.1 ALL METRIC DIMENSIONS ARE IN BRACKETS [X. X]
- 1.2 FOR PATENT INFO: <https://www.adwpat.com>

2.0 DESIGN NOTES

3.0 MANUFACTURING/SPECIAL REQUIREMENTS

- 3.1 TIGHTEN ALL BOLTS 3/8" OR LARGER SECURING FLAT PLATES SNUG TIGHT. TIGHTEN ALL U-BOLTS SNUG TIGHT, WITH ATTENTION TO LEAVE EQUAL DISTANCE AND EQUAL FORCE ON EACH LEG OF U-BOLT.
- 3.2 SNUG TIGHT IS DEFINED AS THE CONDITION OBTAINED WITH A FEW IMPACTS OF AN IMPACT WRENCH OR THE FULL EFFORT OF AN INSTALLER USING AN ORDINARY SPUD WRENCH TO BRING THE CONNECTED LAYERS (PLIES) OF STEEL INTO FULL CONTACT.
- 3.3 FOR BOLTS IN A PATTERN, TIGHTEN IN A CRISS-CROSS OR STAR SEQUENCE, INCREASING TORQUE IN GRADUAL STEPS UNTIL SNUG TIGHT.

4.0 TEST

5.0 PACKAGING

- 5.1 PACKAGING SHALL MEET ANDREW REQUIREMENTS PER DOCUMENT IS-PL-3005
- 5.2 PRINTED DOCUMENT TO BE PLACED INSIDE POLYBAG AND THEN IN SHIPPING CONTAINER
- 5.3 EXTRA HARDWARE MAY BE SUPPLIED, BAGGED AND SHIPPED

REVISIONS			
REV.	DESCRIPTION	DATE	APPROVED
A	INITIAL RELEASE	YX1027 20JAN26	YZ1080 50106914AMO

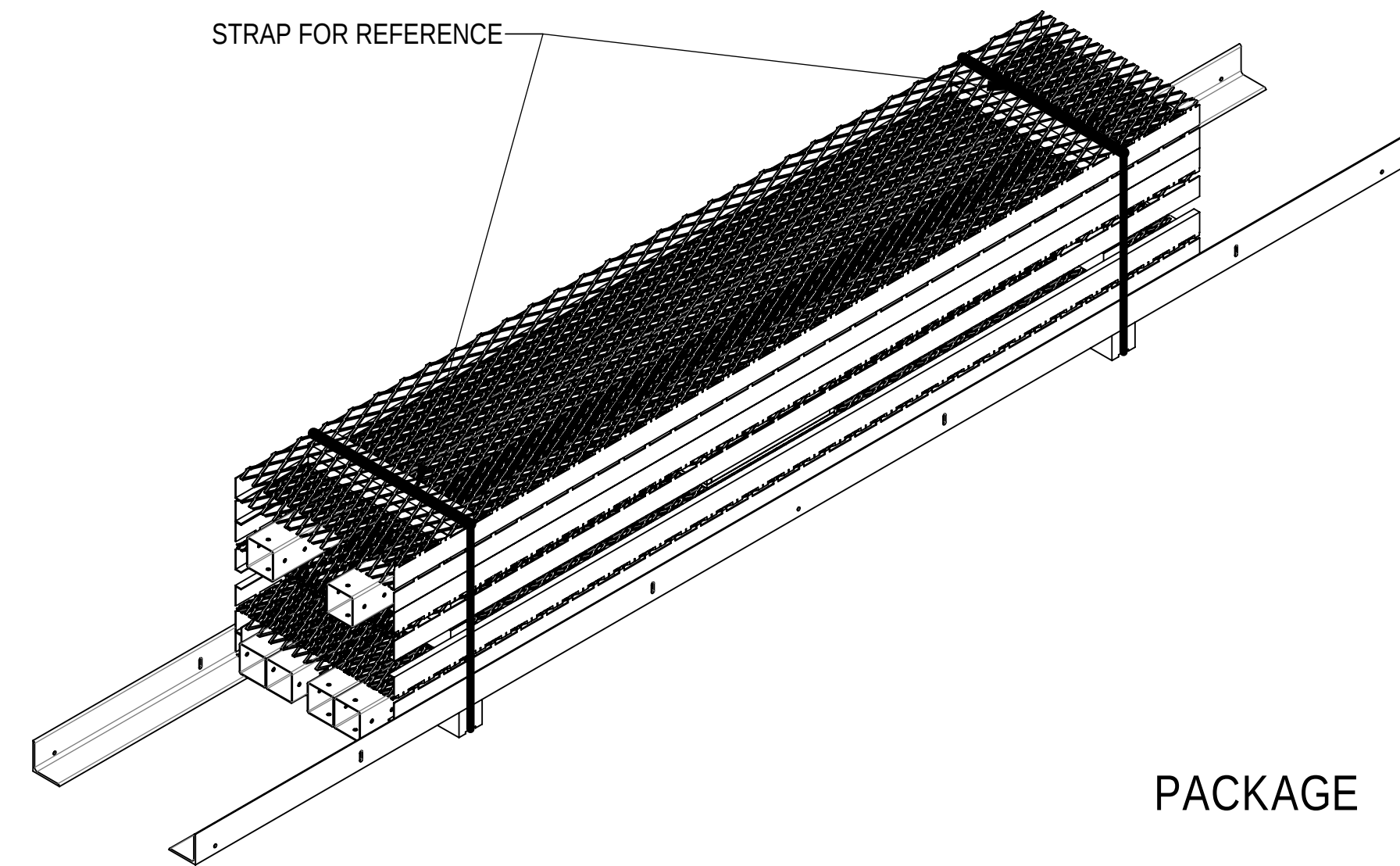
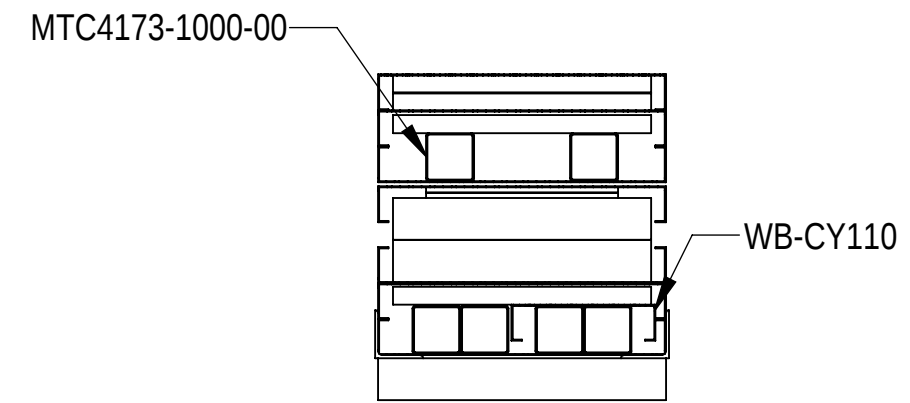
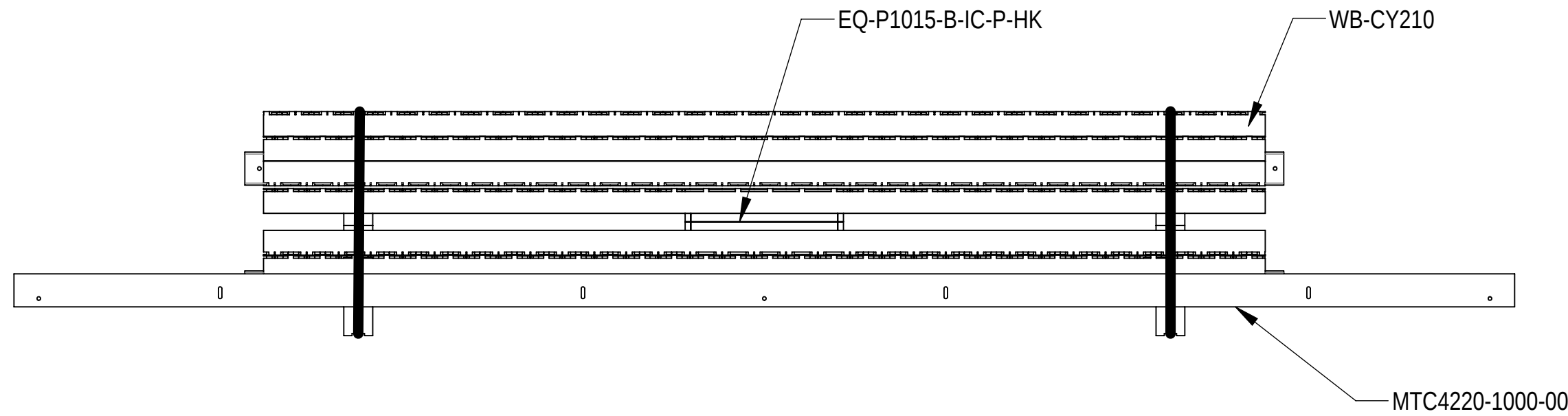



DENSITY	1096.52	lbs/in ³
MASS	1096.52	lbs
VOLUME	3875.87	in ³
SURFACE AREA	64469.04	in ²
HEIGHT	137.7"	
LENGTH	182.0"	
WIDTH	121.5"	

Confidential



ANDREW® an Amphenol company

TOLERANCES		SAP MATERIAL MASTER						
1 PLACE .X[X] ± 0.2[6.3]	3 PLACE .XXX[X] ± 0.060[1.5]	EQ-P1015-B-IC-P						
2 PLACE .XX[X] ± 0.12[3.0]	ANGLES ± 2°							
FINISH		MATERIAL						
UNLESS OTHERWISE SPECIFIED DIMENSIONS ARE IN INCHES INTERPRET PER ANSI Y 14.5M-1994		NAME	DATE	10'X15' ICE CANOPY, ON EQ PLATFORM				
		CE YX1027	20JAN26					
		RW YMENG	02/04/2026					
		AD YZ1080	02/05/2026					
RE YMENG	02/05/2026	SCALE	DOCUMENT NO.	EQ-P1015-B-IC-P				
ECN 50106914AMO		1:24						
SIZE	Auth Group	INSL	MODEL	DRAWING		SHEET 1 OF 3		
C			VERSION	STATUS	REVISION		VERSION	STATUS
			00	RE	A	00	RE	A

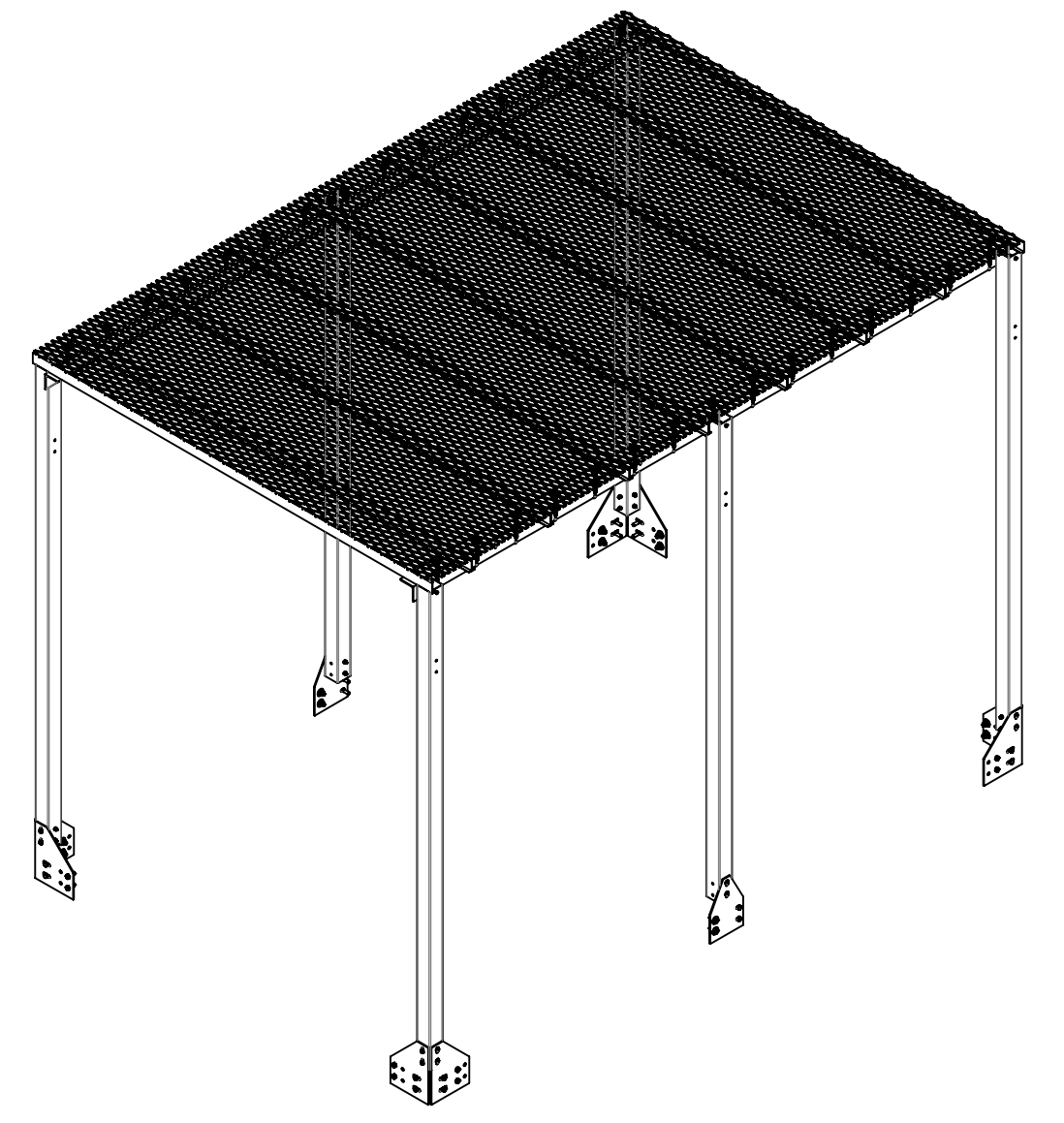
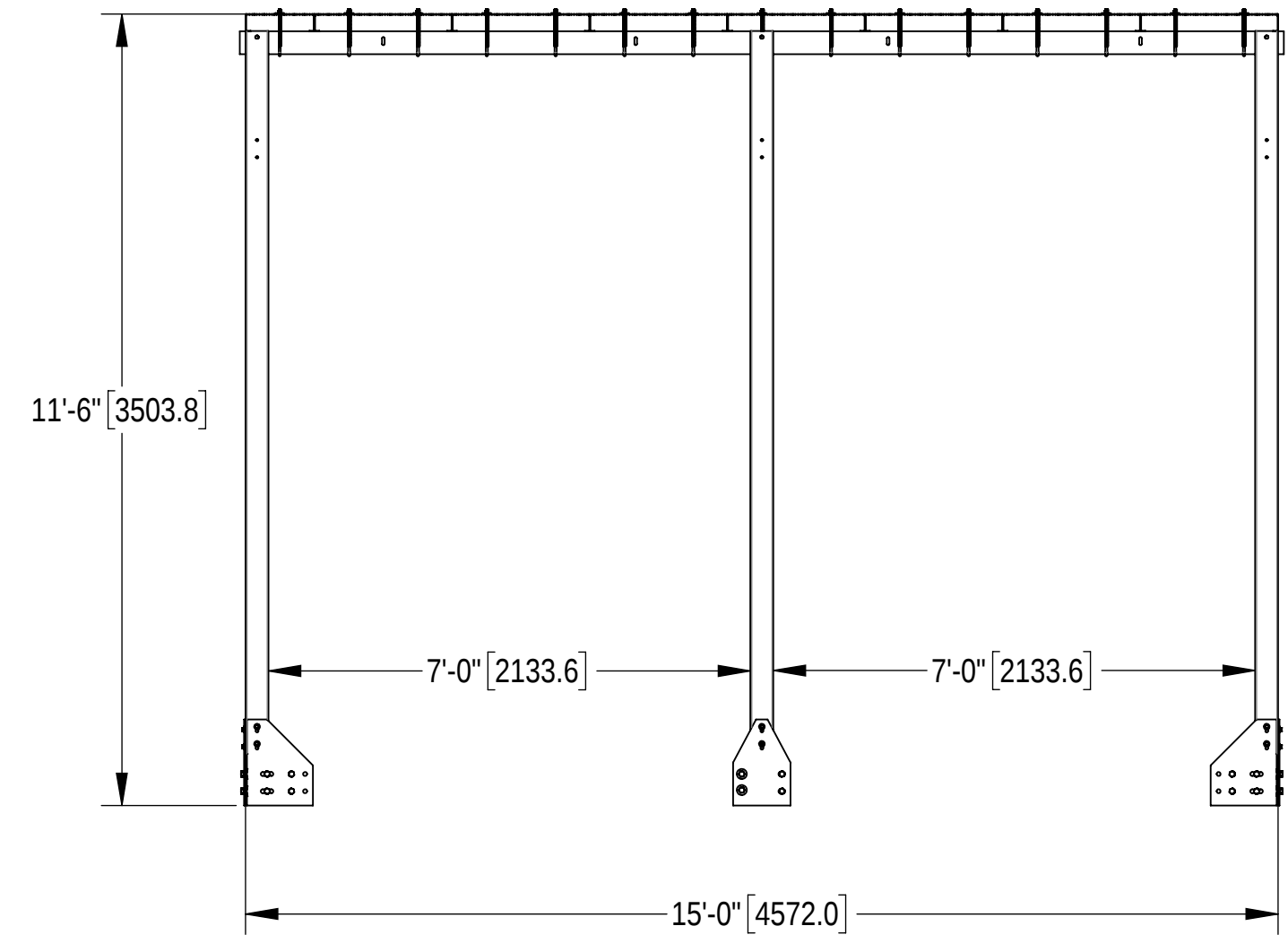
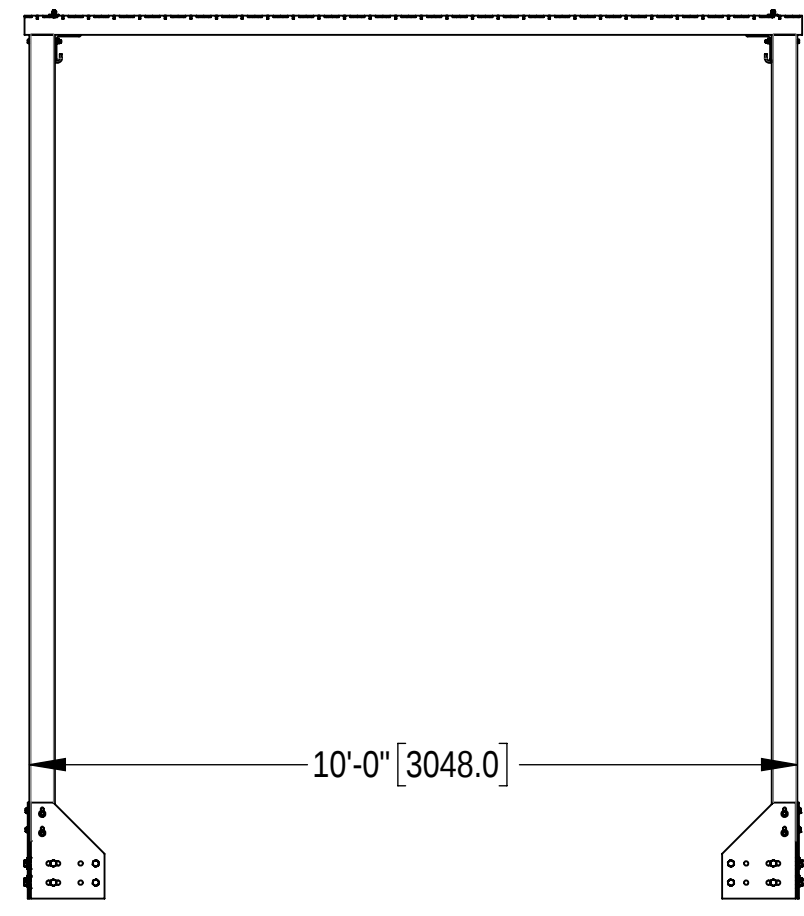
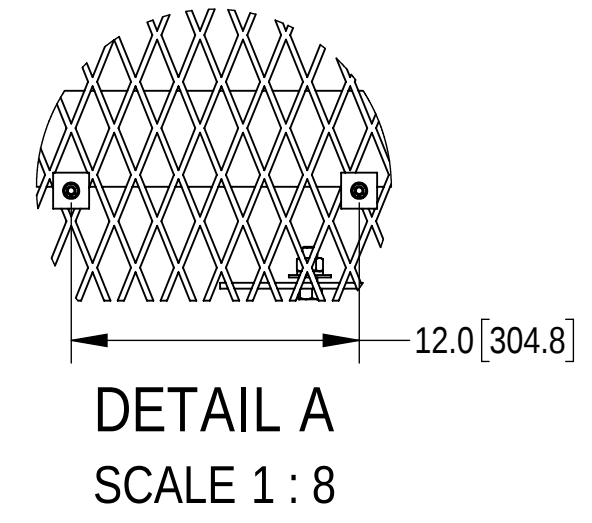
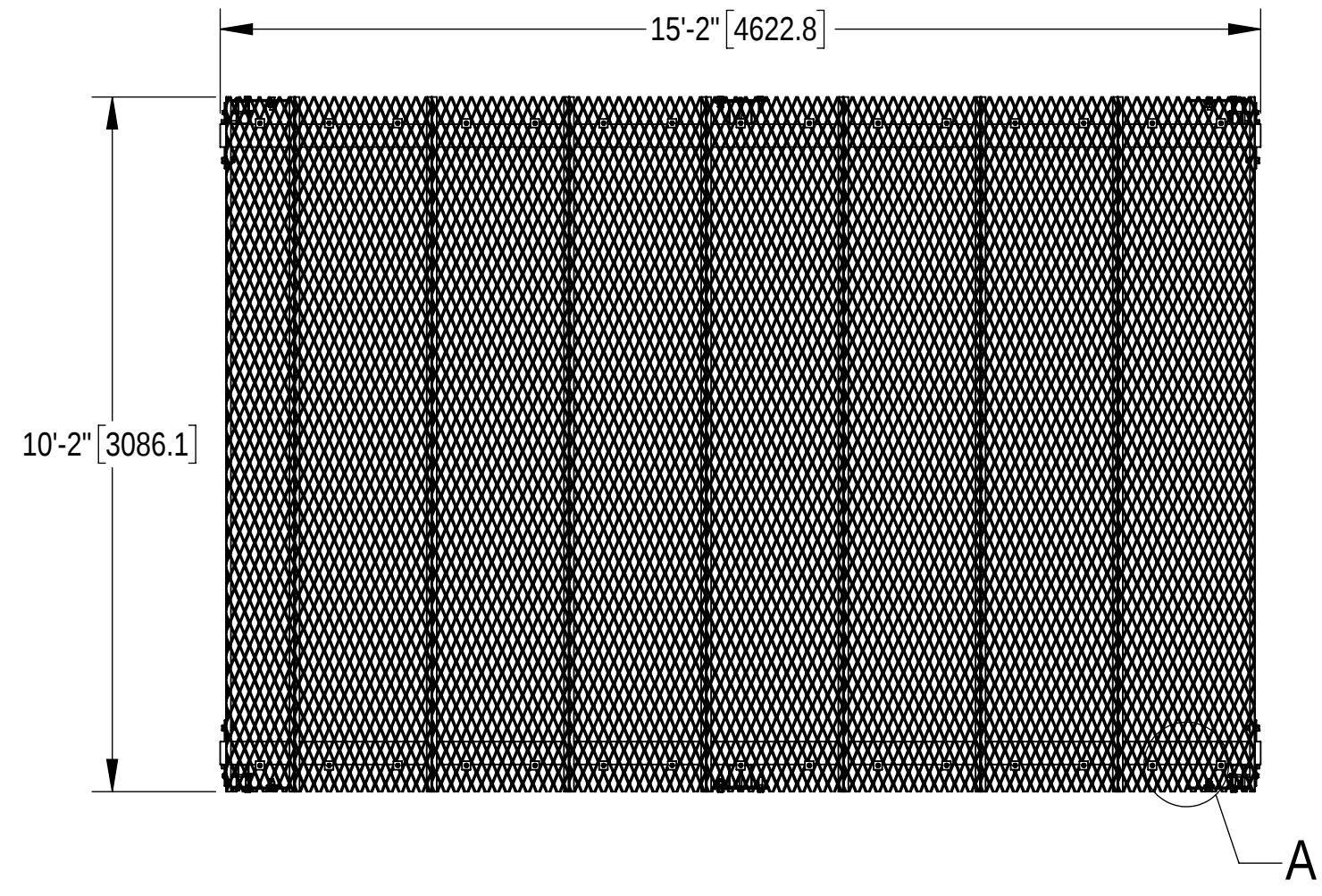

COMPONENT PART NUMBERS PROVIDED FOR ASSEMBLY PURPOSES;
INDIVIDUAL COMPONENTS MAY BE SHIPPED AS PARTS WITHIN AN INCLUDED KIT.

ITEM	PART NO.	DESCRIPTION	QTY.	WEIGHT	NOTE NO.
1	WB-CY210	SAFETY GRATED WAVEGUIDE BRIDGE CHANNEL	7	49.84 LBS	
2	WB-CY110	SAFETY GRATED WAVEGUIDE BRIDGE CHANNEL	1	37.00 LBS	
3	MTC4173-1000-00	POST, 4X4 SQUARE TUBE, 126"	6	64.74 LBS	
4	MTC4220-1000-00	15' ICE SHIELD SUPPORT BRACKET	2	99.34 LBS	
5	GJB0380	8" GALV J-BOLT KIT	30	0.23 LBS	
6	MT-387	SQUARE WASHER 1-1/2"X1-1/2" W/ 7/16 HOLE	30	0.11 LBS	
7	MTC4169-2000-00	PLATE, CANOPY LEG SUPPORT	8	9.59 LBS	
8	MTC4220-2000-00	PLATE, CANOPY LEG SUPPORT,MIDDLE	2	8.24 LBS	
9	GB-03505	3/8" X 5" GALV BOLT KIT	26	0.17 LBS	
10	GB-05165	5/8" X 1-3/4" GALV BOLT KIT	20	0.24 LBS	
11	GWF-03	3/8" GALV FLAT WASHER	20	0.01 LBS	
12	GWL-03	3/8" GALV LOCK WASHER	30	0.01 LBS	
13	GN-03	3/8" GALV HEX NUT	30	0.02 LBS	
14	GB-05225	5/8" X 2-1/4" GALV BOLT KIT	20	0.28 LBS	
15	GWF-05	5/8" GALV FLAT WASHER, 1.70D	24	0.06 LBS	

ANDREW an Amphenol company

TITLE
10'X15' ICE CANOPY, ON EQ PLATFORM

SIZE C	SCALE 1:48	DOCUMENT NO. EQ-P1015-B-IC-P
DRAWING		SHEET
VERSION 00	STATUS RE	REVISION A
Confidential		2 OF 3

4

3

2

1

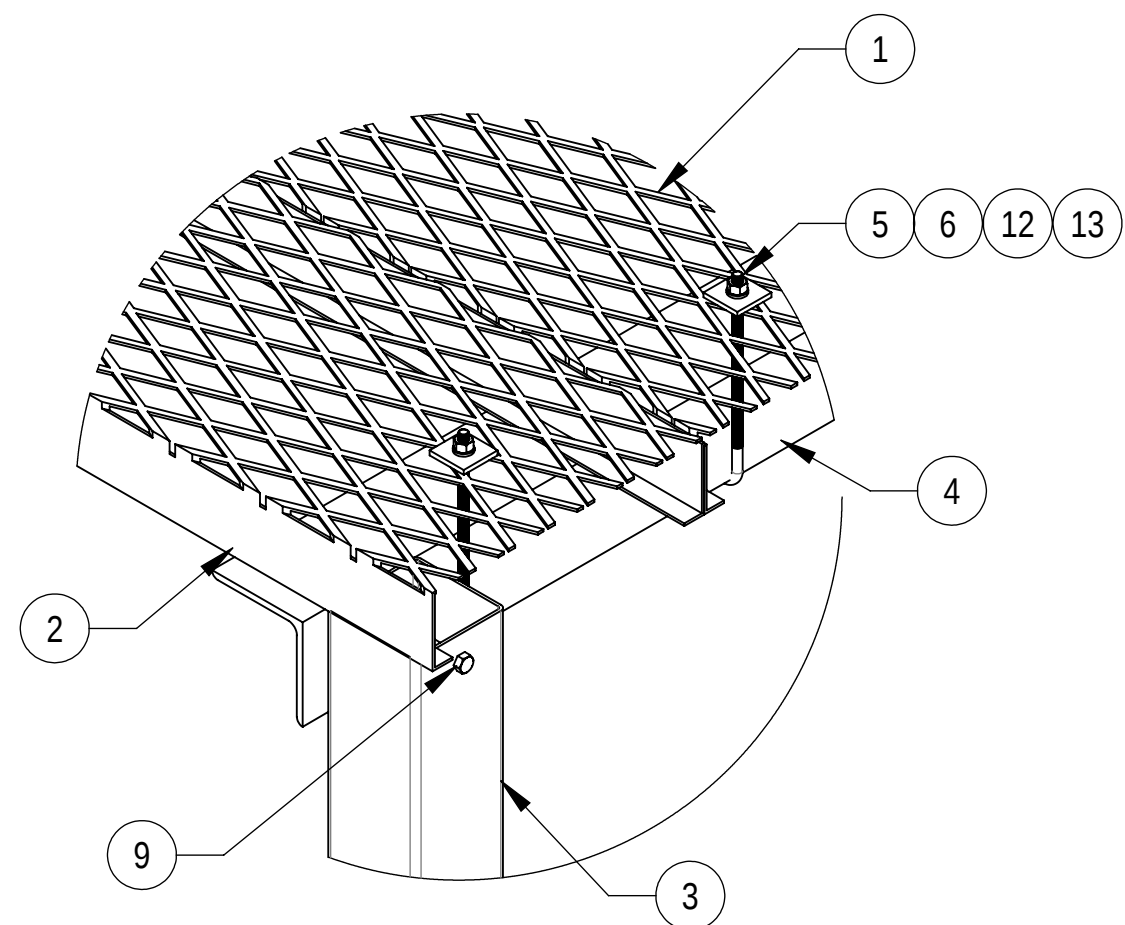

DETAIL B
SCALE 1 : 6

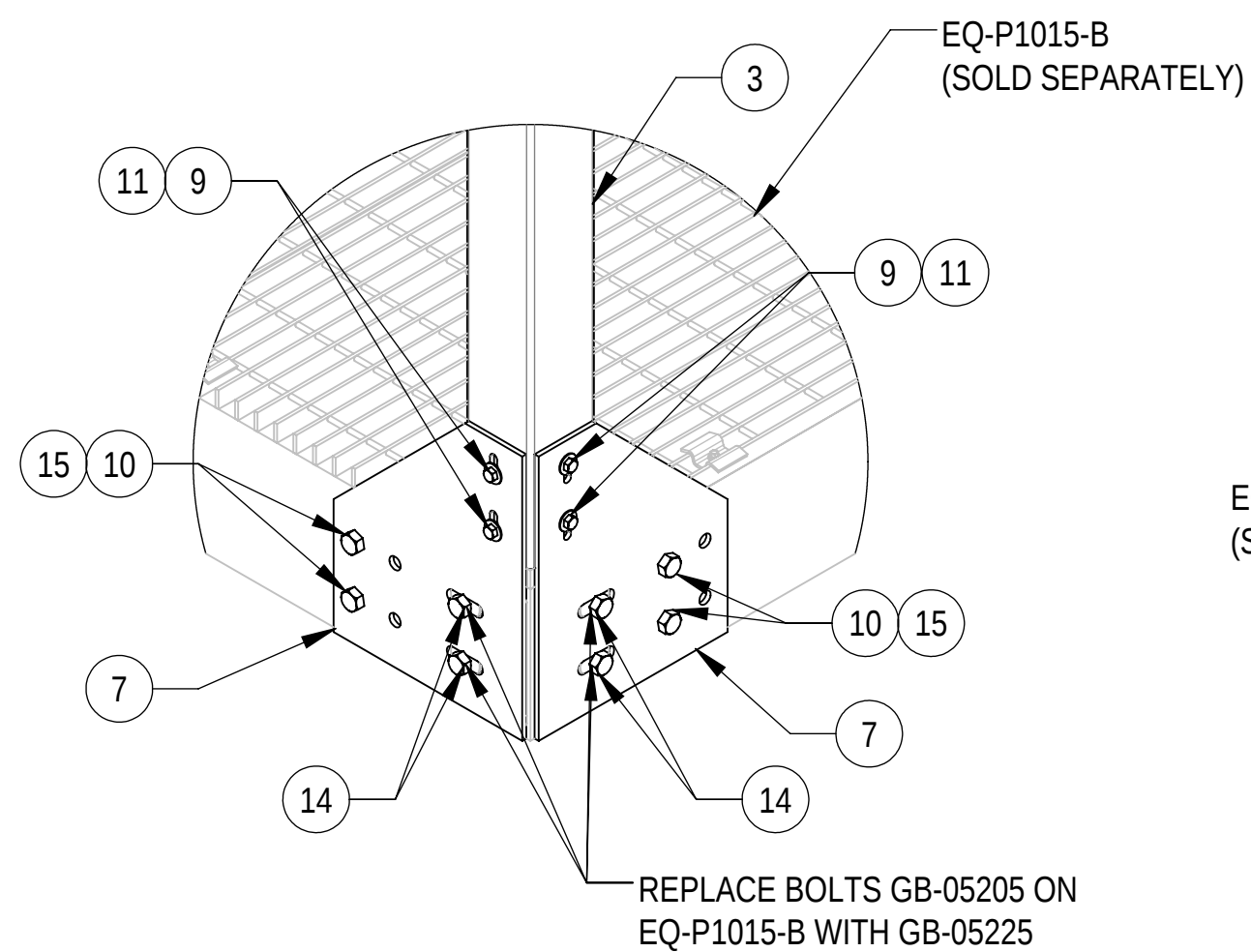
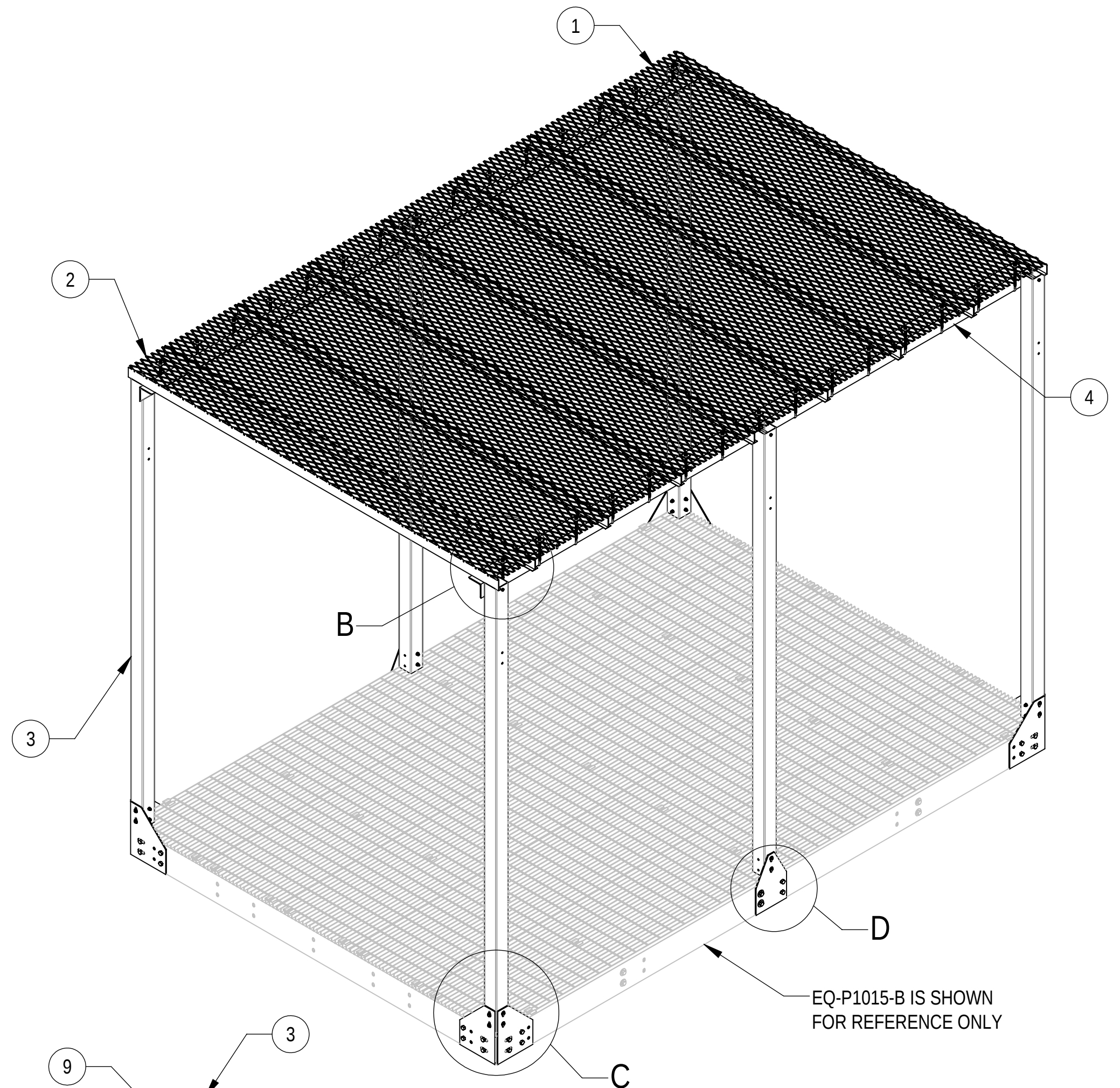

DETAIL C
SCALE 1 : 8
(4 PLACES)

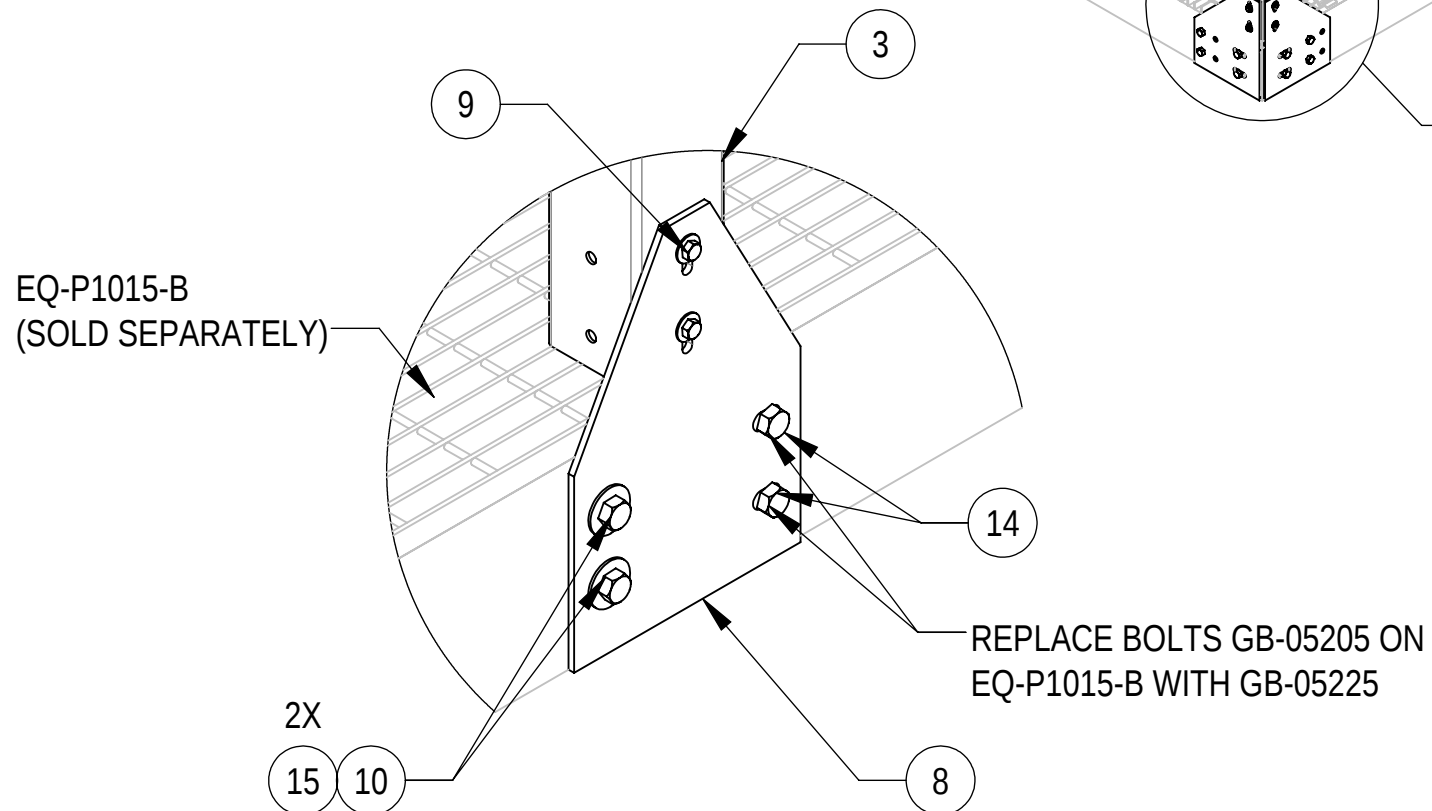

DETAIL D
SCALE 1 : 6
(2 PLACES)



TITLE
10'X15' ICE CANOPY, ON EQ PLATFORM

SIZE C	SCALE 1:48	DOCUMENT NO. EQ-P1015-B-IC-P
------------------	----------------------	--

	DRAWING			SHEET 3 OF 3
	VERSION 00	STATUS RE	REVISION A	

Confidential

4

3

2

1