

F1R-NFQM-M3



FSJ1RK-50B SureFlex® Jumper with interface types N Female and QMA Male, 0.3 Meters

Product Classification

Product Type	SureFlex® standard
Product Brand	HELIAX® SureFlex®
Product Series	FSJ1RK-50B

General Specifications

Body Style, Connector A	Straight
Body Style, Connector B	Straight
Interface, Connector A	N Female
Interface, Connector B	QMA Male
Specification Sheet Revision Level	A

Dimensions

Length	0.3 m 0.984 ft
Nominal Size	1/4 in

VSWR/Return Loss

Frequency Band	VSWR	Return Loss (dB)
700–3000 MHz	1.288	18

Jumper Assembly Sample Label

F1R-NFQM-M3



Environmental Specifications

Immersion Test Method

Meets IEC 60529:2001, IP68 in mated condition

Included Products

- F1TNF-LS – Type N Female for 1/4 in foam and air coaxial cable, factory attached
- F1TQM-LS – QMA Male for HELIAX® Superflexible Foam Coaxial Cable, corrugated copper, 1/4 in, black non-halogenated, fire retardant polyolefin jacket, factory attached
- FSJ1-50A – FSJ1-50A, HELIAX® Superflexible Low Density Foam Coaxial Cable, corrugated copper, 1/4 in, black PE jacket

F1TNF-LS



Type N Female for 1/4 in foam and air coaxial cable, factory attached

Product Classification

Product Type	Wireless and radiating connector
Product Brand	HELIAX® SureFlex®

General Specifications

Body Style	Straight
Cable Family	FSJ1-50A
Inner Contact Attachment Method	Solder
Inner Contact Plating	Silver
Interface	N Female
Mounting Angle	Straight
Outer Contact Attachment Method	Solder
Outer Contact Plating	Trimetal
Pressurizable	No

Dimensions

Length	24.64 mm 0.97 in
Diameter	15.75 mm 0.62 in
Nominal Size	1/4 in

F1TNF-LS

Outline Drawing

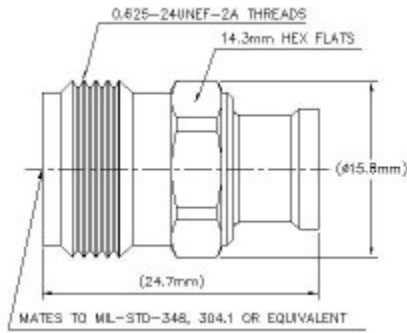

Electrical Specifications

3rd Order IMD at Frequency	-110 dBm @ 910 MHz
3rd Order IMD Test Method	Two +43 dBm carriers
Insertion Loss Coefficient, typical	0.05
Average Power at Frequency	0.4 kW @ 900 MHz
Cable Impedance	50 ohm
Connector Impedance	50 ohm
dc Test Voltage	1600 V
Inner Contact Resistance, maximum	1 mOhm
Insulation Resistance, minimum	5000 MOhm
Operating Frequency Band	0 – 6000 MHz
Outer Contact Resistance, maximum	0.25 mOhm
Peak Power, maximum	6.4 kW
RF Operating Voltage, maximum (vrms)	565 V
Shielding Effectiveness	-110 dB

VSWR/Return Loss

Frequency Band	VSWR	Return Loss (dB)
0–960 MHz	1.036	35.05
1710–2200 MHz	1.046	32.96
2200–2700 MHz	1.065	30.04
2700–3000 MHz	1.065	30.04
3000–6000 MHz	1.152	23.02

F1TNE-LS

Mechanical Specifications

Connector Retention Tensile Force	449.27 N 101 lbf
Connector Retention Torque	1.4 N-m 12.356 in lb
Coupling Nut Proof Torque	1.7 N-m 15.002 in lb
Coupling Nut Proof Torque Method	IEC 61169-16:9.3.11
Coupling Nut Retention Force	445 N 100.04 lbf
Coupling Nut Retention Force Method	IEC 61169-15:9.3.11
Insertion Force	124.55 N 28 lbf
Insertion Force Method	IEC 61169-15:9.3.5
Interface Durability	500 cycles
Interface Durability Method	IEC 61169-4:17
Mechanical Shock Test Method	IEC 60068-2-27

Environmental Specifications

Operating Temperature	-55 °C to +85 °C (-67 °F to +185 °F)
Storage Temperature	-65 °C to +125 °C (-85 °F to +257 °F)
Attenuation, Ambient Temperature	20 °C 68 °F
Average Power, Ambient Temperature	40 °C 104 °F
Average Power, Inner Conductor Temperature	100 °C 212 °F
Corrosion Test Method	IEC 60068-2-11
Immersion Depth	1 m
Immersion Test Mating	Mated
Immersion Test Method	IEC 60529:2001, IP68
Moisture Resistance Test Method	IEC 60068-2-3
Thermal Shock Test Method	IEC 60068-2-14
Vibration Test Method	IEC 60068-2-6

Packaging and Weights

Weight, net	18.33 g 0.04 lb
--------------------	-------------------

Regulatory Compliance/Certifications

Agency	Classification
CHINA-ROHS	Below maximum concentration value

F1TNF-LS

REACH-SVHC	Compliant as per SVHC revision on www.andrew.com/ProductCompliance
ROHS	Compliant
UK-ROHS	Compliant



* Footnotes

Insertion Loss Coefficient, typical $0.05\sqrt{\text{freq}}$ (GHz) (not applicable for elliptical waveguide)

Immersion Depth Immersion at specified depth for 24 hours

F1TQM-LS

QMA Male for HELIAX® Superflexible Foam Coaxial Cable, corrugated copper, 1/4 in, black non-halogenated, fire retardant polyolefin jacket, factory attached

Product Classification

Product Type	Wireless and radiating connector
Product Brand	HELIAX® SureFlex®

General Specifications

Body Style	Straight
Inner Contact Attachment Method	Solder
Inner Contact Plating	Gold
Interface	QMA Male
Outer Contact Attachment Method	Solder
Outer Contact Plating	Trimetal
Pressurizable	No

Dimensions

Length	23.11 mm 0.91 in
Diameter	10.92 mm 0.43 in
Nominal Size	1/4 in

Electrical Specifications

3rd Order IMD at Frequency	-100 dBm @ 1800 MHz
Insertion Loss Coefficient, typical	0.05
Average Power at Frequency	0.4 kW @ 900 MHz
Cable Impedance	50 ohm
Connector Impedance	50 ohm
dc Test Voltage	1000 V
Inner Contact Resistance, maximum	3 mOhm
Insulation Resistance, minimum	5000 MOhm
Operating Frequency Band	0 – 6000 MHz
Outer Contact Resistance, maximum	2.5 mOhm
Peak Power, maximum	5 kW

F1TQM-LS

RF Operating Voltage, maximum (vrms)	500 V
Shielding Effectiveness	-110 dB

VSWR/Return Loss

Frequency Band	VSWR	Return Loss (dB)
824–2200 MHz	1.05	33.2
2200–4000 MHz	1.05	32.26
4000–6000 MHz	1.1	26.45

Mechanical Specifications

Connector Retention Tensile Force	57.83 N 13 lbf
Connector Retention Torque	1.4 N-m 12.391 in lb
Insertion Force	97.86 N 22 lbf
Insertion Force Method	IEC 61169-15:9.3.5
Interface Durability	500 cycles
Interface Durability Method	IEC 61169-4:17
Mechanical Shock Test Method	IEC 60068-2-27

Environmental Specifications

Operating Temperature	-55 °C to +85 °C (-67 °F to +185 °F)
Storage Temperature	-65 °C to +125 °C (-85 °F to +257 °F)
Attenuation, Ambient Temperature	20 °C 68 °F
Average Power, Ambient Temperature	40 °C 104 °F
Average Power, Inner Conductor Temperature	100 °C 212 °F
Corrosion Test Method	IEC 60068-2-11
Moisture Resistance Test Method	IEC 60068-2-3
Thermal Shock Test Method	IEC 60068-2-14
Vibration Test Method	IEC 60068-2-6

Packaging and Weights

Weight, net	7.59 g 0.017 lb
--------------------	-------------------

Regulatory Compliance/Certifications

Agency	Classification
---------------	-----------------------

F1TQM-LS

CHINA-ROHS	Below maximum concentration value
ISO 9001:2015	Designed, manufactured and/or distributed under this quality management system
REACH-SVHC	Compliant as per SVHC revision on www.andrew.com/ProductCompliance
ROHS	Compliant
UK-ROHS	Compliant



* Footnotes

Insertion Loss Coefficient, typical $0.05\sqrt{\text{freq (GHz)}}$ (not applicable for elliptical waveguide)

FSJ1-50A



FSJ1-50A, HELIAX® Superflexible Low Density Foam Coaxial Cable, corrugated copper, 1/4 in, black PE jacket

Product Classification

Product Type	Coaxial wireless cable
Product Brand	HELIAX® SureFlex®
Product Series	FSJ1-50A MLOC

General Specifications

Product Number	887009902/00 SZ887009902/00
Flexibility	Superflexible
Jacket Color	Black
Performance Note	Attenuation values typical, guaranteed within 5%

Dimensions

Diameter Over Dielectric	4.826 mm 0.19 in
Diameter Over Jacket	7.366 mm 0.29 in
Inner Conductor OD	1.905 mm 0.075 in
Outer Conductor OD	6.35 mm 0.25 in
Nominal Size	1/4 in

Electrical Specifications

Cable Impedance	50 ohm ±1 ohm
Capacitance	79.4 pF/m 24.201 pF/ft
dc Resistance, Inner Conductor	9.843 ohms/km 3 ohms/kft
dc Resistance, Outer Conductor	7.216 ohms/km 2.199 ohms/kft
dc Test Voltage	1600 V
Inductance	0.2 µH/m 0.061 µH/ft
Insulation Resistance	100000 MOhms-km
Jacket Spark Test Voltage (rms)	5000 V
Operating Frequency Band	1 – 18000 MHz

FSJ1-50A

Peak Power 6.4 kW

Velocity 82 %

Attenuation

Frequency (MHz)	Attenuation (dB/100 m)	Attenuation (dB/100 ft)	Average Power (kW)
1.0	0.577	0.176	6.4
1.5	0.707	0.215	6.4
2.0	0.816	0.249	6.4
10.0	1.833	0.559	3.99
20.0	2.6	0.792	2.81
30.0	3.192	0.973	2.29
50.0	4.136	1.261	1.77
85.0	5.419	1.652	1.35
88.0	5.516	1.681	1.33
100.0	5.889	1.795	1.24
108.0	6.125	1.867	1.19
150.0	7.25	2.21	1.01
174.0	7.825	2.385	0.93
200.0	8.408	2.563	0.87
204.0	8.495	2.589	0.86
300.0	10.373	3.162	0.71
400.0	12.051	3.673	0.61
450.0	12.817	3.906	0.57
460.0	12.965	3.952	0.56
500.0	13.545	4.128	0.54
512.0	13.715	4.18	0.53
600.0	14.909	4.544	0.49
700.0	16.175	4.93	0.45
800.0	17.362	5.292	0.42
824.0	17.637	5.376	0.41
894.0	18.42	5.614	0.4
960.0	19.134	5.832	0.38
1000.0	19.556	5.96	0.37
1218.0	21.738	6.626	0.34
1250.0	22.044	6.719	0.33

FSJ1-50A

1500.0	24.326	7.414	0.3
1700.0	26.038	7.936	0.28
1794.0	26.813	8.172	0.27
1800.0	26.862	8.187	0.27
2000.0	28.455	8.673	0.26
2100.0	29.227	8.908	0.25
2200.0	29.984	9.139	0.24
2300.0	30.727	9.365	0.24
2500.0	32.174	9.806	0.23
2700.0	33.576	10.233	0.22
3000.0	35.602	10.851	0.21
3400.0	38.183	11.638	0.19
3600.0	39.428	12.017	0.19
3700.0	40.041	12.204	0.18
3800.0	40.647	12.389	0.18
3900.0	41.247	12.571	0.18
4000.0	41.841	12.753	0.17
4100.0	42.429	12.932	0.17
4200.0	43.012	13.11	0.17
4300.0	43.59	13.286	0.17
4400.0	44.163	13.46	0.17
4500.0	44.73	13.633	0.16
4600.0	45.293	13.805	0.16
4700.0	45.852	13.975	0.16
4800.0	46.405	14.144	0.16
4900.0	46.955	14.311	0.16
5000.0	47.5	14.477	0.15
6000.0	52.747	16.077	0.14
8000.0	62.37	19.01	0.12
8800.0	65.974	20.108	0.11
10000.0	71.173	21.693	0.1
12000.0	79.393	24.198	0.09
14000.0	87.172	26.569	0.08
15800.0	93.872	28.611	0.08
16000.0	94.601	28.833	0.08

FSJ1-50A

18000.0 101.745 31.01 0.07

VSWR/Return Loss

Frequency Band	VSWR	Return Loss (dB)
680–960 MHz	1.201	20.8
1700–2200 MHz	1.201	20.8
2200–2700 MHz	1.433	15

Material Specifications

Dielectric Material	Foam PE
Jacket Material	PE
Inner Conductor Material	Copper-clad aluminum wire
Outer Conductor Material	Corrugated copper

Mechanical Specifications

Minimum Bend Radius, multiple Bends	25.4 mm 1 in
Minimum Bend Radius, single Bend	25.4 mm 1 in
Number of Bends, minimum	15
Number of Bends, typical	20
Tensile Strength	68 kg 149.914 lb
Bending Moment	0.7 N-m 6.196 in lb
Flat Plate Crush Strength	1.8 kg/mm 100.795 lb/in

Environmental Specifications

Installation temperature	-40 °C to +60 °C (-40 °F to +140 °F)
Operating Temperature	-55 °C to +85 °C (-67 °F to +185 °F)
Storage Temperature	-70 °C to +85 °C (-94 °F to +185 °F)
Attenuation, Ambient Temperature	68 °F 20 °C
Average Power, Ambient Temperature	104 °F 40 °C
Average Power, Inner Conductor Temperature	212 °F 100 °C

Packaging and Weights

Cable weight	0.07 kg/m 0.047 lb/ft
---------------------	-------------------------

Regulatory Compliance/Certifications

FSJ1-50A

Agency

Classification

CHINA-ROHS

Below maximum concentration value

ISO 9001:2015

Designed, manufactured and/or distributed under this quality management system

ROHS

Compliant

UK-ROHS

Compliant

UL/ETL Certification

Compliant

