

- 1.0 GENERAL NOTES
- 1.1 ALL METRIC DIMENSIONS ARE IN BRACKETS [X. X]
- 1.2 FOR PATENT INFO: <https://www.adwpat.com>

- 2.0 DESIGN NOTES
- 2.1 ANY HAZARDS OR OBSTRUCTIONS TO THE CLIMBING FACILITY AND SAFETY CLIMB MUST BE IDENTIFIED PRIOR TO INSTALLING THE APPURTENANCE. ADDITIONAL PRODUCTS MAY BE REQUIRED TO MAINTAIN THE INTEGRITY OF THE SAFETY CLIMB. DURING INSTALLATION, TEMPORARY AND/OR PERMANENT PRECAUTIONARY MEASURES SHOULD BE TAKEN TO PRESERVE THE CLIMBING FACILITY AND/OR SAFETY CLIMB.

- 3.0 MANUFACTURING/SPECIAL REQUIREMENTS
- 3.1 TIGHTEN ALL BOLTS SECURING FLAT PLATES BY THE TURN-OF-NUT METHOD. TIGHTEN ALL U-BOLTS USING TURN-OF-NUT METHOD WITH ATTENTION TO LEAVE EQUAL DISTANCE AND EQUAL FORCE ON EACH LEG OF THE U-BOLT.

- 4.0 TEST
- 5.0 PACKAGING
- 5.1 PACKAGING SHALL MEET ANDREW REQUIREMENTS PER DOCUMENT IS-PL-3005
- 5.2 PRINTED DOCUMENT TO BE PLACED INSIDE POLYBAG AND THEN IN SHIPPING CONTAINER
- 5.3 EXTRA HARDWARE MAY BE SUPPLIED, BAGGED AND SHIPPED

REVISIONS			
REV.	DESCRIPTION	DATE	APPROVED
A	INITIAL RELEASE	MRC 04APR18	TP
B	UPDATED DRAWING FORMAT TO NEW	JJ1095 31OCT25	BA1025 50105606AMO

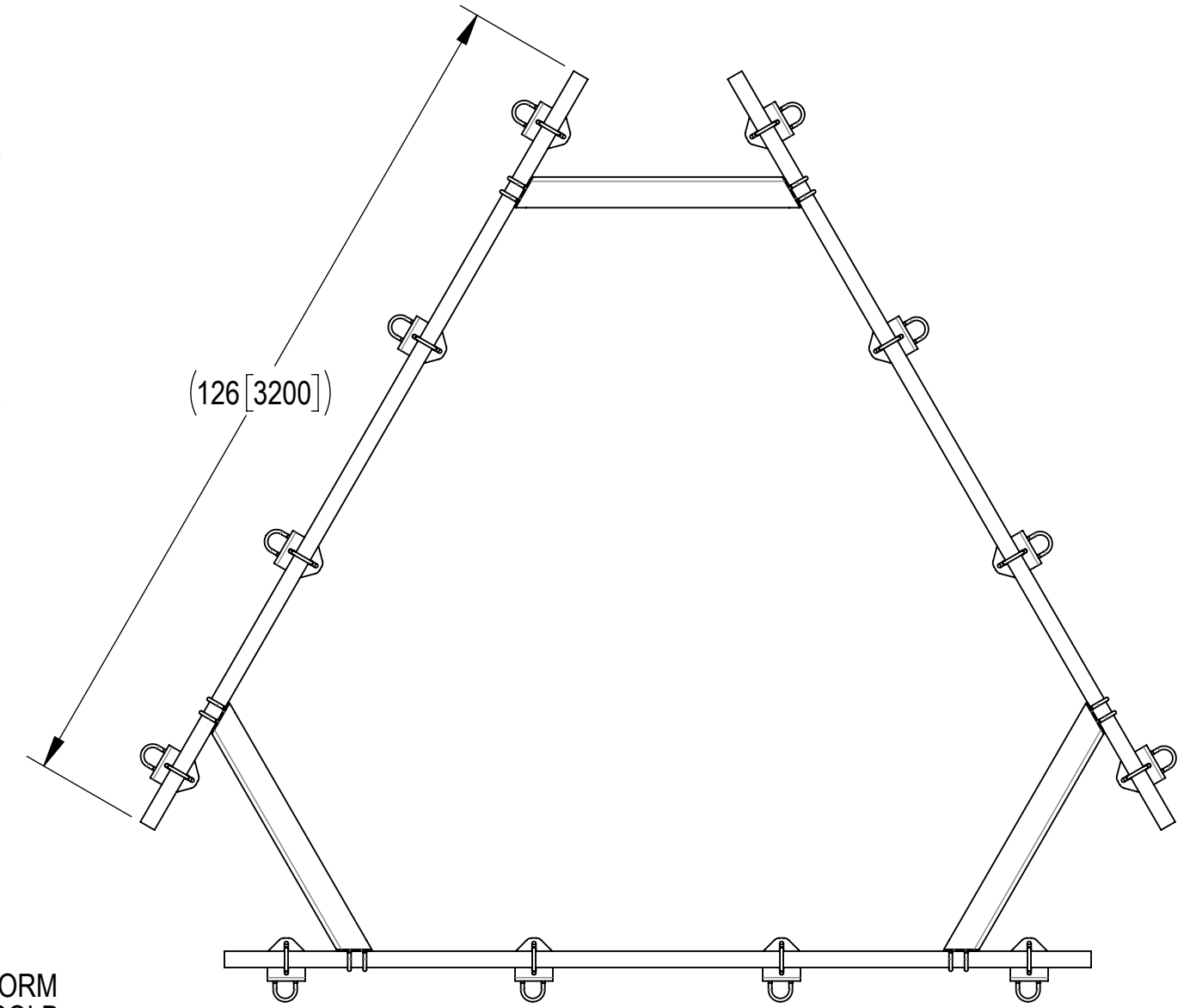
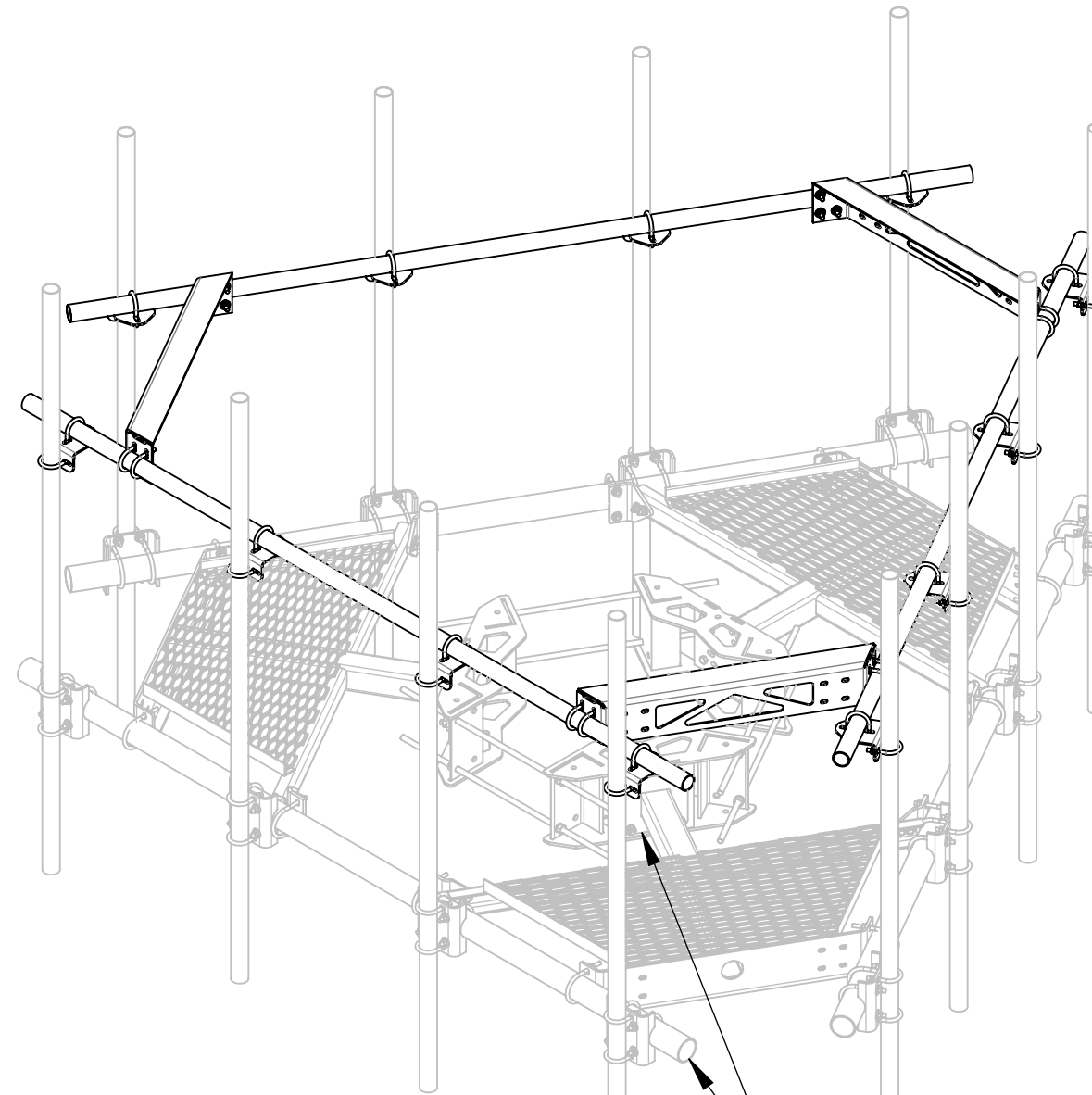
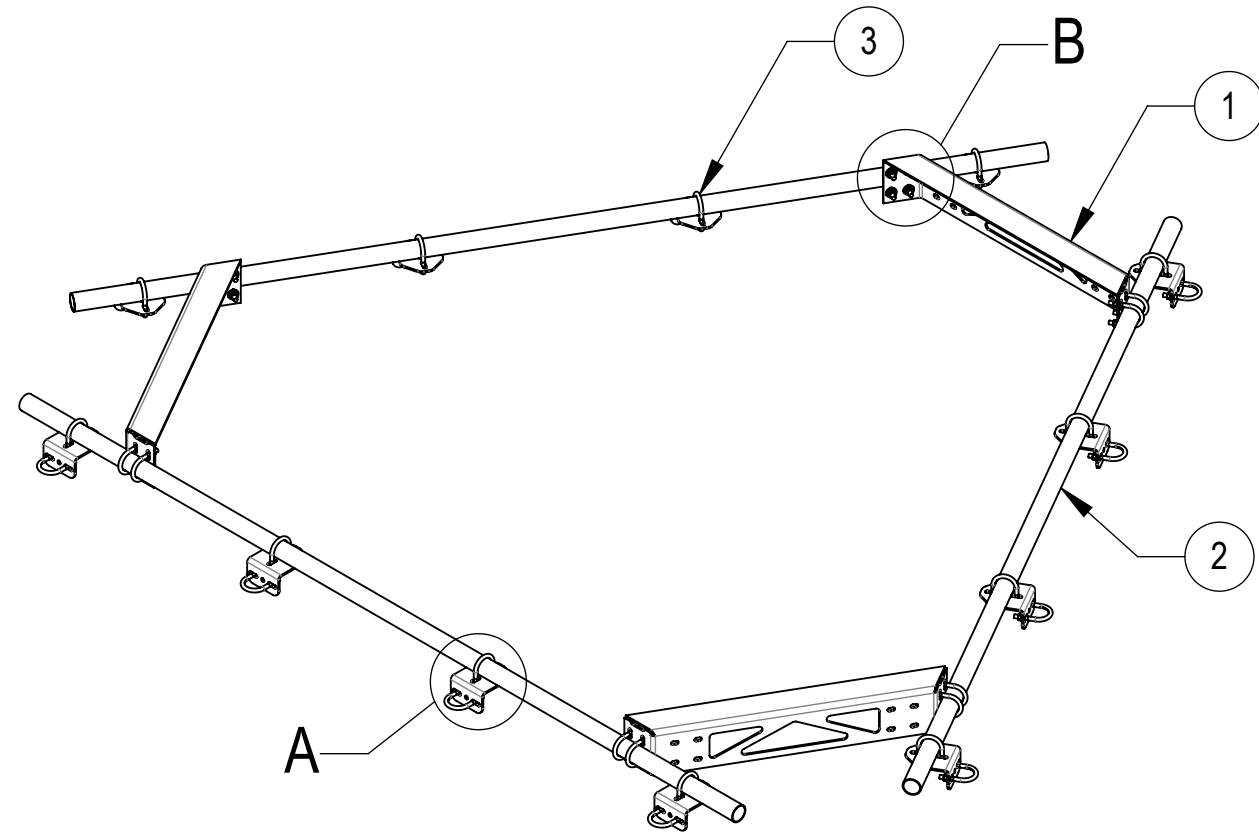

RING MOUNT PLATFORM AND PIPE MOUNTS SOLD SEPARATELY

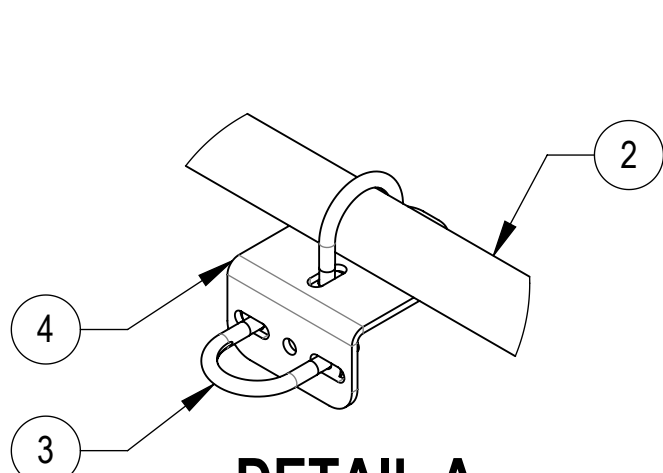

DETAIL A
SCALE 1 : 6

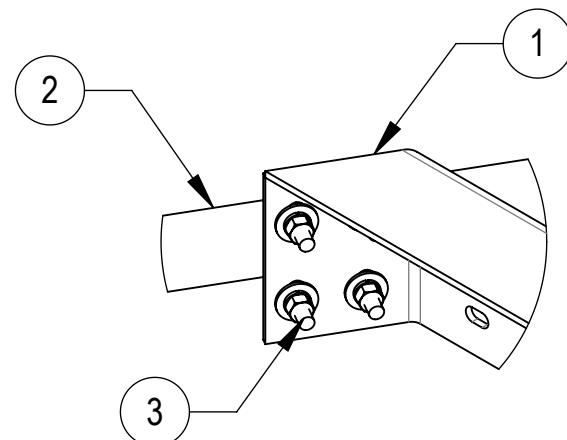

DETAIL B
SCALE 1 : 6

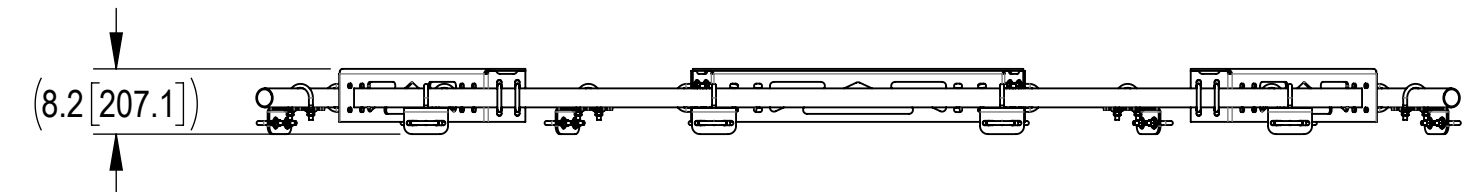

COMPONENT PART NUMBERS PROVIDED FOR ASSEMBLY PURPOSES; INDIVIDUAL COMPONENTS MAY BE SHIPPED AS PARTS WITHIN AN INCLUDED KIT.

ITEM	PART NO.	DESCRIPTION	QTY.	WEIGHT	NOTE NO.
1	MT195801	CORNER WELDMENT SNUB NOSE HANDRAIL	3	26.94 LBS	
2	MT-537	2.375" OD X 126" PIPE	3	30.45 LBS	
3	GUB-4240	1/2" X 2-1/2" X 4" GALV U-BOLT	36	0.56 LBS	
4	XAU01	ANGLE, CROSSOVER, 1.9-3.5" X 1.9-3.5" OD	12	2.98 LBS	

DENSITY	235.03	lbs/in ³
MASS	235.03	lbs
VOLUME	829.40	in ³
SURFACE AREA	10053.53	in ²
HEIGHT	8.2"	
LENGTH	150.9"	
WIDTH	150.9"	

Confidential

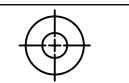
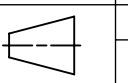

ANDREW® an Amphenol company

TOLERANCES		SAP MATERIAL MASTER	
1 PLACE .X[X] ± 0.2[6.3]	3 PLACE .XXX[X] ± 0.060[1.5]	MT-195-10	
2 PLACE .XX[X] ± 0.12[3.0]	ANGLES ± 2°		
FINISH		MATERIAL	
<small>UNLESS OTHERWISE SPECIFIED DIMENSIONS ARE IN INCHES INTERPRET PER ANSI Y 14.5M-1994</small>		NAME	DATE
		CE MRC	04/04/2018
		RW JJ1095	11/03/2025
		AD YMENG	11/04/2025
RE YMENG	11/19/2025	HANDRAIL FOR MC-PK10-B	
ECN 50105606AMO	SCALE 1:24	DOCUMENT NO. MT-195-10	
SIZE	Auth Group	INSL	MODEL
C	 	VERSION	STATUS
		03	RE
DRAWING		VERSION	STATUS
		01	RE
		REVISION	REVISION
		D	B
			SHEET
			1 OF 1