

- 1.0 GENERAL NOTES  
 1.1 ALL METRIC DIMENSIONS ARE IN BRACKETS [X. X]  
 1.2 FOR PATENT INFO: <https://www.adwpat.com>  
 2.0 DESIGN NOTES  
 3.0 MANUFACTURING/SPECIAL REQUIREMENTS  
 3.1 BUS BAR SHOWN IN VARIOUS MOUNTING CONFIGURATIONS  
 3.2 TIGHTEN ALL BOLTS SNUG TIGHT, DEFINED AS THE CONDITION OBTAINED WITH THE FULL EFFORT OF AN ASSEMBLER USING AN ORDINARY SPUD WRENCH TO BRING THE CONNECTING SURFACES INTO FIRM CONTACT  
 4.0 TEST  
 5.0 PACKAGING  
 5.1 PACKAGING SHALL MEET ANDREW REQUIREMENTS PER DOCUMENT IS-PL-3005  
 5.2 PRINTED DOCUMENT TO BE PLACED INSIDE POLYBAG AND THEN IN SHIPPING CONTAINER  
 5.3 EXTRA HARDWARE MAY BE SUPPLIED, BAGGED AND SHIPPED

REVISIONS			
REV.	DESCRIPTION	DATE	APPROVED
A	INITIAL RELEASE	HC 26FEB14	TP
B	UPDATED DRAWING FORMAT; GB0316-4 (ITEM 8) WAS SB0316#4 PER SAP BOM	YC1059 10OCT25	BA1025 50105304AMO

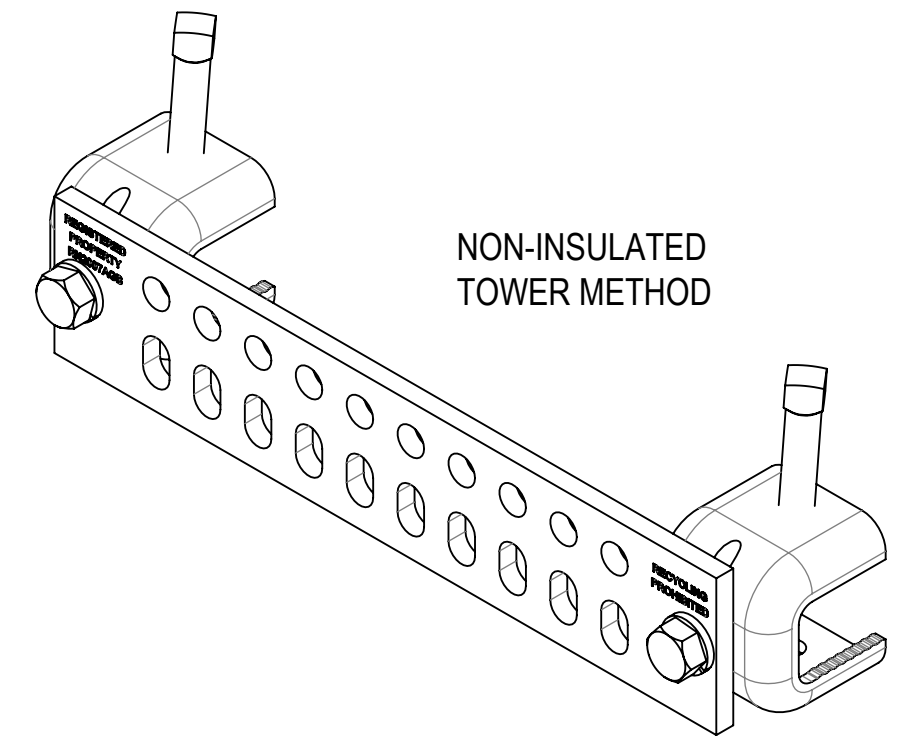
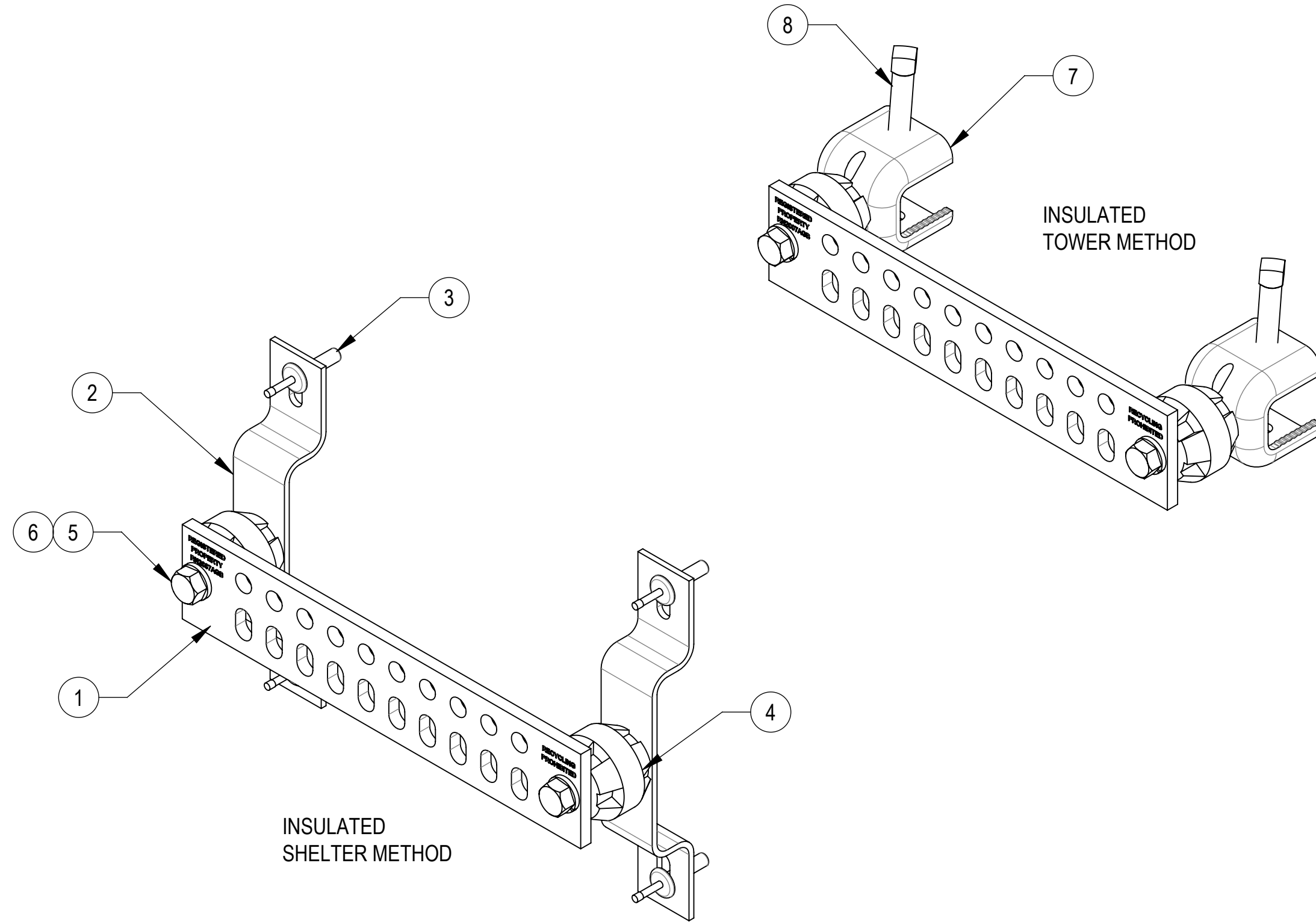

COMPONENT PART NUMBERS PROVIDED FOR ASSEMBLY PURPOSES;  
 INDIVIDUAL COMPONENTS MAY BE SHIPPED AS PARTS WITHIN AN INCLUDED KIT.

ITEM NO.	PART NUMBER	DESCRIPTION	QTY.	WEIGHT	NOTE NO.
1	CBB0210P01T	GROUND BUSS BAR 2X10 TINNED	1	1.28 LBS	
2	MT500GDP	STANDOFF BRACKET	2	0.33 LBS	
3	DPA141ZP	6.5 X 25mm DRIVE PIN ANCHOR	4	0.02 LBS	
4	MT520	INSULATOR W/ 3/8" INSERT	2	0.21 LBS	
5	SB0305	3/8" X 5/8" SS BOLT	4	0.04 LBS	
6	SWL-03	3/8" SS LOCK WASHER	4	0.01 LBS	
7	45840G-1	HANGER CLAMP	2	0.38 LBS	
8	GB0316-4	SQUARE HEAD SET SCREW, 3/8-16X1-3/4	2	0.07 LBS	

DENSITY		lbs/in <sup>3</sup>
MASS	3.47	lbs
VOLUME	17.98	in <sup>3</sup>
SURFACE AREA	201.51	in <sup>2</sup>
HEIGHT		
LENGTH		
WIDTH		

**ANDREW**® an Amphenol company

TOLERANCES  
 1 PLACE .X[X] ± 0.12[3.0]    3 PLACE .XXX[X] ± 0.030[0.8]  
 2 PLACE .XX[X] ± 0.06[1.5]    ANGLES ± 2°

SAP MATERIAL MASTER  
**CBB-0210T-1MU**

FINISH: \_\_\_\_\_ MATERIAL: \_\_\_\_\_

UNLESS OTHERWISE SPECIFIED DIMENSIONS ARE IN INCHES INTERPRET PER ANSI Y 14.5M-1994	NAME	DATE	TITLE
CE	HC	25FEB14	<b>GROUND BUS BAR KIT TIN 2X10</b>
RW	YC1059	10/10/2025	
AD	YMENG	10/13/2025	
RE	YMENG	10/14/2025	

SCALE: **1:2**    DOCUMENT NO.: **CBB-0210T-1MU**

ECN 50105304AMO

SIZE	Auth Group	INSL	MODEL			DRAWING			SHEET
<b>C</b>			VERSION	STATUS	REVISION	VERSION	STATUS	REVISION	1 OF 1
			01	RE	<b>B</b>	01	RE	<b>B</b>	

Confidential