

# C400-NFUM-1M

---

CNT-400 CNT® Jumper with interface types N Female and UHF Male, 1



m

## Product Classification

<b>Product Type</b>	Braided cable assembly
<b>Product Brand</b>	CNT®
<b>Product Series</b>	CNT-400

## General Specifications

<b>Body Style, Connector A</b>	Straight
<b>Body Style, Connector B</b>	Straight
<b>Cable Family</b>	CNT-400
<b>Interface, Connector A</b>	N Female
<b>Interface, Connector B</b>	UHF Male
<b>Specification Sheet Revision Level</b>	A

## Dimensions

<b>Length</b>	1 m   3.281 ft
<b>Nominal Size</b>	0.400 in

## VSWR/Return Loss

Frequency Band	VSWR	Return Loss (dB)
45–400 MHz	1.288	18

## Jumper Assembly Sample Label

# C400-NFUM-1M

---



## Included Products

- 400PUM – UHF Male for CNT-400 braided cable
- CNT-400 – CNT-400, CNT® 50 Ohm Braided Coaxial Cable, variable, black PE jacket

# 400PUM

---



UHF Male for CNT-400 braided cable

## Product Classification

<b>Product Type</b>	Braided cable connector
<b>Product Brand</b>	CNT®

## General Specifications

<b>Body Style</b>	Straight
<b>Inner Contact Attachment Method</b>	Solder
<b>Inner Contact Plating</b>	Silver
<b>Interface</b>	UHF Male
<b>Outer Contact Attachment Method</b>	Clamp
<b>Outer Contact Plating</b>	Trimetal
<b>Pressurizable</b>	No

## Dimensions

<b>Width</b>	22.35 mm   0.88 in
<b>Length</b>	46.1 mm   1.815 in
<b>Diameter</b>	22.35 mm   0.88 in
<b>Nominal Size</b>	0.405 in

## Outline Drawing

# 400PUM

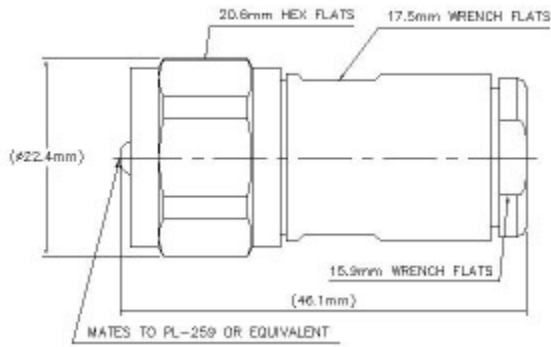

## Electrical Specifications

<b>Insertion Loss, typical</b>	0.05 dB
<b>Average Power at Frequency</b>	580.0 W @ 900 MHz
<b>Cable Impedance</b>	50 ohm
<b>Connector Impedance</b>	50 ohm
<b>dc Test Voltage</b>	1500 V
<b>Inner Contact Resistance, maximum</b>	6 mOhm
<b>Insulation Resistance, minimum</b>	5000 MOhm
<b>Operating Frequency Band</b>	0 – 1000 MHz
<b>Outer Contact Resistance, maximum</b>	9 mOhm
<b>RF Operating Voltage, maximum (vrms)</b>	500 V

## VSWR/Return Loss

Frequency Band	VSWR	Return Loss (dB)
0–300 MHz	1.433	14.99
300–600 MHz	1.433	14.99
600–1000 MHz	1.671	12

## Mechanical Specifications

<b>Connector Retention Tensile Force</b>	330 N   74.187 lbf
<b>Connector Retention Torque</b>	0.56 N-m   4.956 in lb   0.75 N-m   6.638 in lb
<b>Coupling Nut Proof Torque</b>	1.7 N-m   15.046 in lb
<b>Interface Durability</b>	500 cycles
<b>Interface Durability Method</b>	IEC 61169-12:9.5
<b>Mechanical Shock Test Method</b>	IEC 60068-2-27

# 400PUM

---

## Environmental Specifications

<b>Operating Temperature</b>	-40 °C to +85 °C (-40 °F to +185 °F)
<b>Storage Temperature</b>	-65 °C to +125 °C (-85 °F to +257 °F)
<b>Attenuation, Ambient Temperature</b>	20 °C   68 °F
<b>Average Power, Ambient Temperature</b>	40 °C   104 °F
<b>Average Power, Inner Conductor Temperature</b>	100 °C   212 °F
<b>Climatic Sequence Test Method</b>	IEC 60068-1
<b>Corrosion Test Method</b>	IEC 60068-2-11
<b>Damp Heat Steady State Test Method</b>	IEC 60068-2-3
<b>Immersion Depth</b>	1 m
<b>Immersion Test Mating</b>	Mated
<b>Immersion Test Method</b>	IEC 60529:2001, IP68
<b>Thermal Shock Test Method</b>	IEC 60068-2-14
<b>Vibration Test Method</b>	IEC 60068-2-6

## Packaging and Weights

<b>Weight, net</b>	73 g   0.161 lb
--------------------	-----------------

## Regulatory Compliance/Certifications

<b>Agency</b>	<b>Classification</b>
CHINA-ROHS	Below maximum concentration value
ISO 9001:2015	Designed, manufactured and/or distributed under this quality management system
REACH-SVHC	Compliant as per SVHC revision on <a href="http://www.andrew.com/ProductCompliance">www.andrew.com/ProductCompliance</a>
ROHS	Compliant
UK-ROHS	Compliant



## \* Footnotes

<b>Insertion Loss, typical</b>	0.05√freq (GHz) (not applicable for elliptical waveguide)
<b>Immersion Depth</b>	Immersion at specified depth for 24 hours

# CNT-400

---



CNT-400, CNT® 50 Ohm Braided Coaxial Cable, variable, black PE jacket

## Product Classification

<b>Product Type</b>	Braided coaxial cable
<b>Product Brand</b>	CNT®
<b>Product Series</b>	CNT-400

## General Specifications

<b>Braid Coverage</b>	90 %
<b>Cable Type</b>	CNT-400
<b>Jacket Color</b>	Black

## Dimensions

<b>Diameter Over Dielectric</b>	7.24 mm   0.285 in
<b>Diameter Over Jacket</b>	10.29 mm   0.405 in
<b>Diameter Over Tape</b>	7.391 mm   0.291 in
<b>Inner Conductor OD</b>	2.74 mm   0.108 in
<b>Outer Conductor OD</b>	8.08 mm   0.318 in
<b>Nominal Size</b>	0.400 in

## Electrical Specifications

<b>Cable Impedance</b>	50 ohm
<b>Capacitance</b>	78 pF/m   23.774 pF/ft
<b>dc Resistance, Inner Conductor</b>	4.69 ohms/km   1.43 ohms/kft
<b>dc Resistance, Outer Conductor</b>	5.61 ohms/km   1.71 ohms/kft
<b>dc Test Voltage</b>	2500 V
<b>Jacket Spark Test Voltage (rms)</b>	4000 V
<b>Maximum Frequency</b>	16.2 GHz
<b>Operating Frequency Band</b>	30 – 6000 MHz
<b>Peak Power</b>	16 kW

# CNT-400

---

<b>Shielding Effectiveness</b>	90 dB
<b>Velocity</b>	85 %

## Attenuation

<b>Frequency (MHz)</b>	<b>Attenuation (dB/100 m)</b>	<b>Attenuation (dB/100 ft)</b>
30.0	2.49	0.76
50.0	3.18	0.97
150.0	4.92	1.5
220.0	6.23	1.9
450.0	8.86	2.7
900.0	12.8	3.9
1500.0	16.7	5.1
1800.0	18.4	5.6
2000.0	19.4	5.9
2400.0	21.65	6.6
2500.0	22	6.7
3000.0	24.6	7.5
4000.0	28.87	8.8
4500.0	30.84	9.4
5000.0	32.81	10
5200.0	33.46	10.2
5500.0	34.78	10.6
5800.0	35.76	10.9
6000.0	36.42	11.1

## Material Specifications

<b>Braid Material</b>	Tinned copper
<b>Dielectric Material</b>	Foam PE
<b>Jacket Material</b>	Non-halogenated PE
<b>Inner Conductor Material</b>	Copper-clad aluminum wire
<b>Shield Tape Material</b>	Aluminum

## Mechanical Specifications

<b>Minimum Bend Radius, single Bend</b>	25.4 mm   1 in
<b>Tensile Strength</b>	73 kg   160.937 lb

# CNT-400

---

<b>Bending Moment</b>	0.7 N-m   6.196 in lb
<b>Flat Plate Crush Strength</b>	0.7 kg/mm   39.198 lb/in

## Environmental Specifications

<b>Installation temperature</b>	-40 °C to +85 °C (-40 °F to +185 °F)
<b>Operating Temperature</b>	-40 °C to +85 °C (-40 °F to +185 °F)
<b>Storage Temperature</b>	-70 °C to +85 °C (-94 °F to +185 °F)

## Packaging and Weights

<b>Cable weight</b>	0.1 kg/m   0.067 lb/ft
---------------------	------------------------

## Regulatory Compliance/Certifications

<b>Agency</b>	<b>Classification</b>
CHINA-ROHS	Below maximum concentration value
ISO 9001:2015	Designed, manufactured and/or distributed under this quality management system
REACH-SVHC	Compliant as per SVHC revision on <a href="http://www.andrew.com/ProductCompliance">www.andrew.com/ProductCompliance</a>
ROHS	Compliant
UK-ROHS	Compliant

