

- 1.0 GENERAL NOTES
 1.1 ALL METRIC DIMENSIONS ARE IN BRACKETS [X. X]
 1.2 FOR PATENT INFO: <https://www.adwpat.com>
 2.0 DESIGN NOTES
 3.0 MANUFACTURING/SPECIAL REQUIREMENTS
 3.1 TIGHTEN ALL BOLTS 3/8" OR LARGER SECURING FLAT PLATES SNUG TIGHT. TIGHTEN ALL U-BOLTS/THREADED RODS SNUG TIGHT, WITH ATTENTION TO LEAVE EQUAL DISTANCE AND EQUAL FORCE ON EACH LEG OF U-BOLT/THREADED ROD.
 3.2 SNUG TIGHT IS DEFINED AS THE CONDITION OBTAINED WITH A FEW IMPACTS OF AN IMPACT WRENCH OR THE FULL EFFORT OF AN INSTALLER USING AN ORDINARY SPUD WRENCH TO BRING THE CONNECTED LAYERS (PLIES) OF STEEL INTO FULL CONTACT.
 3.3 FOR BOLTS IN A PATTERN, TIGHTEN IN A CRISS-CROSS OR STAR SEQUENCE, INCREASING TORQUE IN GRADUAL STEPS UNTIL SNUG TIGHT.
 4.0 TEST
 5.0 PACKAGING
 5.1 PACKAGING SHALL MEET ANDREW REQUIREMENTS PER DOCUMENT IS-PL-3005
 5.2 PRINTED DOCUMENT TO BE PLACED INSIDE POLYBAG AND THEN IN SHIPPING CONTAINER
 5.3 EXTRA HARDWARE MAY BE SUPPLIED, BAGGED AND SHIPPED

REVISIONS			
REV.	DESCRIPTION	DATE	APPROVED
A	INITIAL RELEASE	MRC 19MAR19	RD1048
B	UPDATED DRAWING FORMAT TO NEW	LL1090 05DEC25	BA1025 50106106AMO

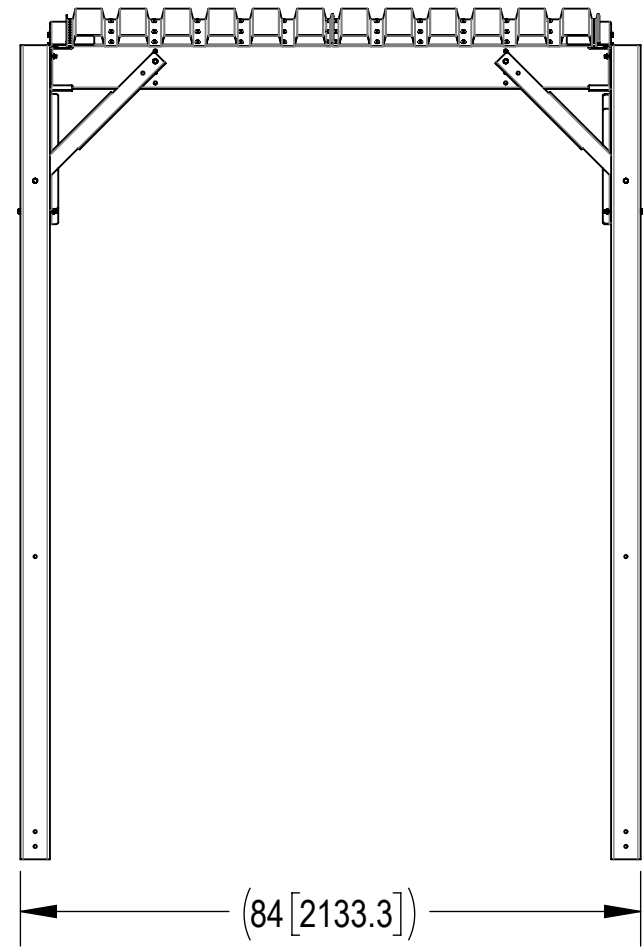
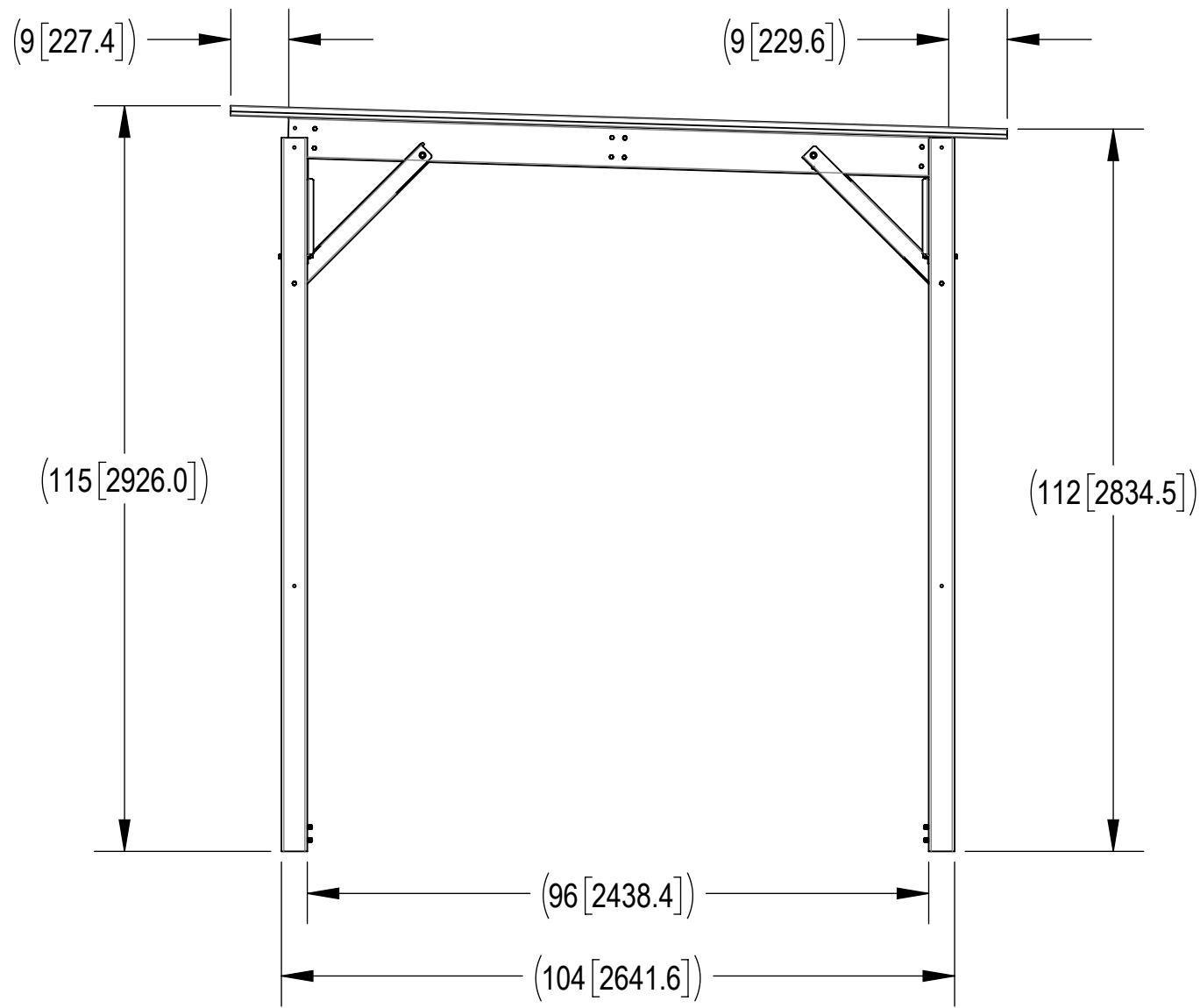
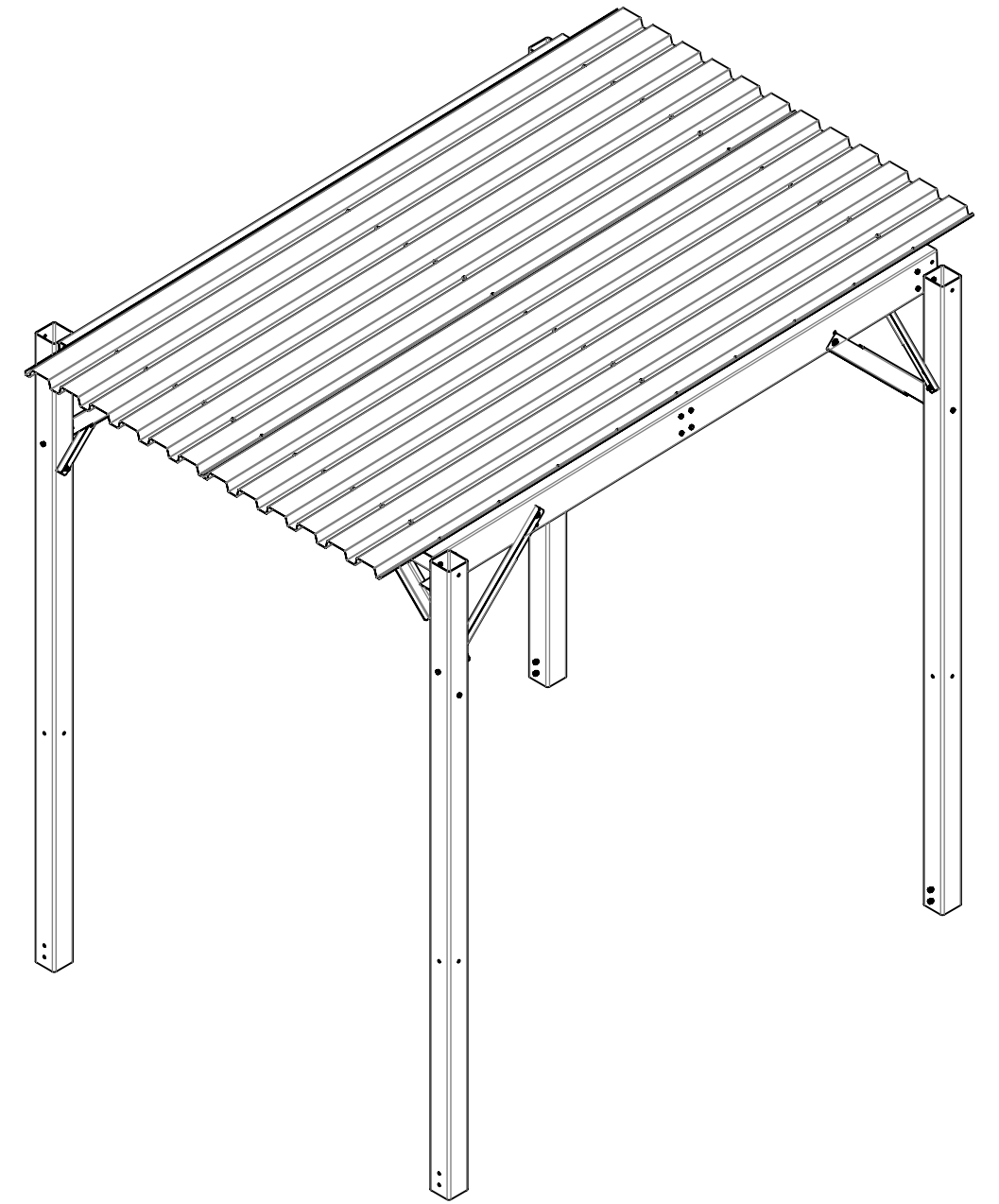
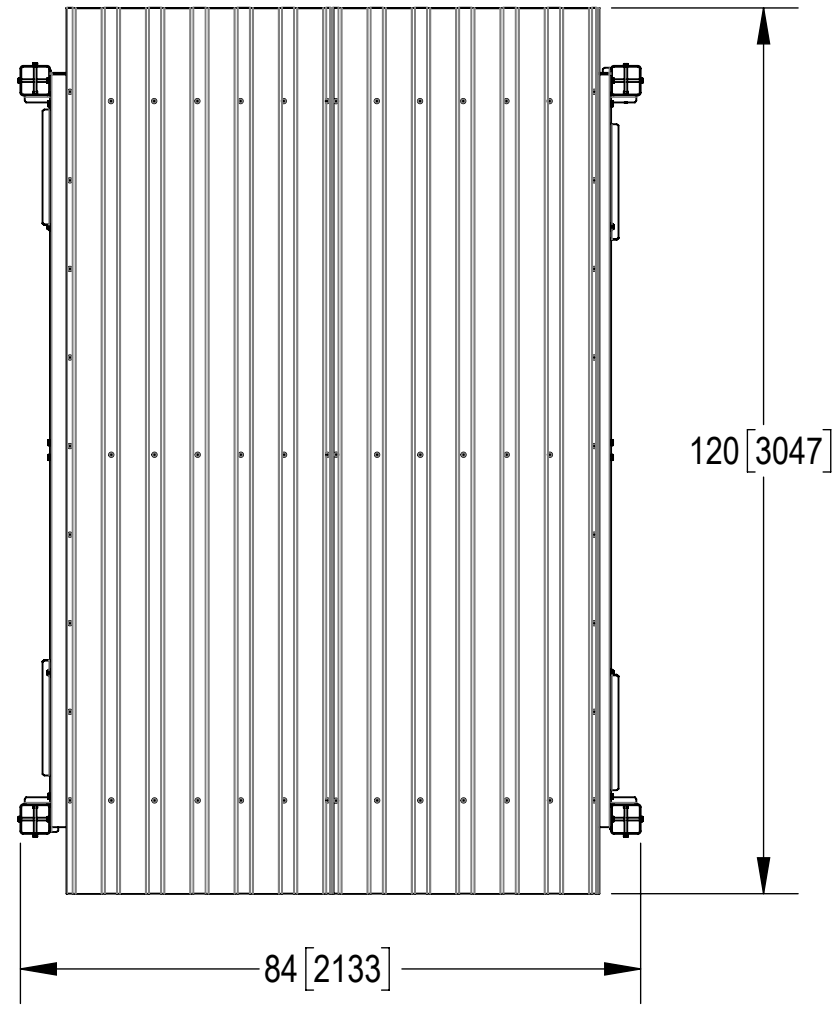

COMPONENT PART NUMBERS PROVIDED FOR ASSEMBLY PURPOSES;
 INDIVIDUAL COMPONENTS MAY BE SHIPPED AS PARTS WITHIN AN INCLUDED KIT.

ITEM	PART NO.	DESCRIPTION	QTY.	WEIGHT	NOTE NO.
1	MTC3813C14	CANOPY BRACE, 11 GA, 30"	4	4.18 LBS	
2	MTC392212	CANOPY BRACE, 11GA, 24.5"	4	2.75 LBS	
3	MTC4037C16	POST, 4 X 4 X 110.25	4	56 LBS	
4	MTC4037C14	CHANNEL FORMED CANOPY END, 8' PLAT	2	51.15 LBS	
5	MTC4037C15	CHANNEL FORMED CANOPY, 8' PLATFORM	4	18.30 LBS	
6	RDB1836120	ROOF DECKING B 18 GA 36" X 120"	2	82.34 LBS	
7	GB-03105	3/8" X 1" GALV BOLT KIT	36	0.05 LBS	
8	GB-03505	3/8" X 5" GALV BOLT KIT	8	0.17 LBS	
9	GWF-03	3/8" GALV FLAT WASHER	8	0.01 LBS	
10	TS1275	TEK SCREW #12 X 3/4, WITH NEOPRENE WASHER	54	0.02 LBS	

DENSITY		lbs/in ³
MASS	596.35	lbs
VOLUME	2111.08	in ³
SURFACE AREA	50071.94	in ²
HEIGHT	115"	
LENGTH	120"	
WIDTH	84"	

ANDREW® an Amphenol company

TOLERANCES: 0 PLACE X[X] ± .25[6.3] 2 PLACE .XX[X] ± 0.06[1.5] 1 PLACE .X[X] ± 0.12[3.0] ANGLES ± 2°

SAP MATERIAL MASTER: **MTC4037CRHD**

FINISH: _____ MATERIAL: _____

UNLESS OTHERWISE SPECIFIED DIMENSIONS ARE IN INCHES INTERPRET PER ANSI Y 14.5M-1994

REV.	NAME	DATE	TITLE
CE	MRC	06/26/18	8'X8' HD 18GA, PROT PLAT CAN
RW	LL1090	12/11/2025	
AD	YMENG	12/12/2025	
RE	YMENG	12/12/2025	

SCALE: **1:26** DOCUMENT NO.: **MTC4037CRHD**

ECN 50106106AMO

SIZE	Auth Group	INSL	MODEL	DRAWING			SHEET	
C	[Symbol]	[Symbol]	VERSION	STATUS	REVISION	VERSION	STATUS	REVISION
			02	RE	C	01	RE	B

Confidential

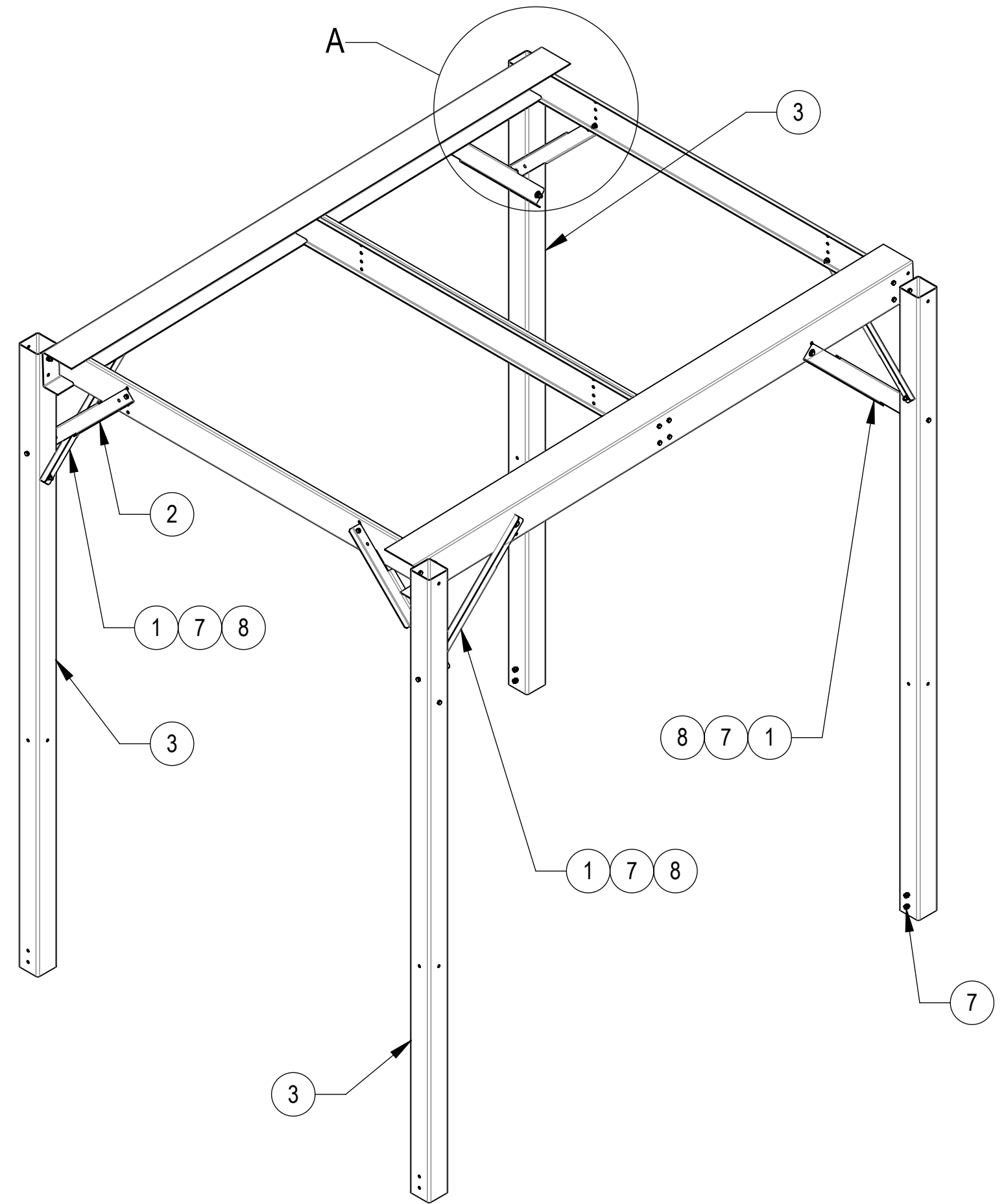
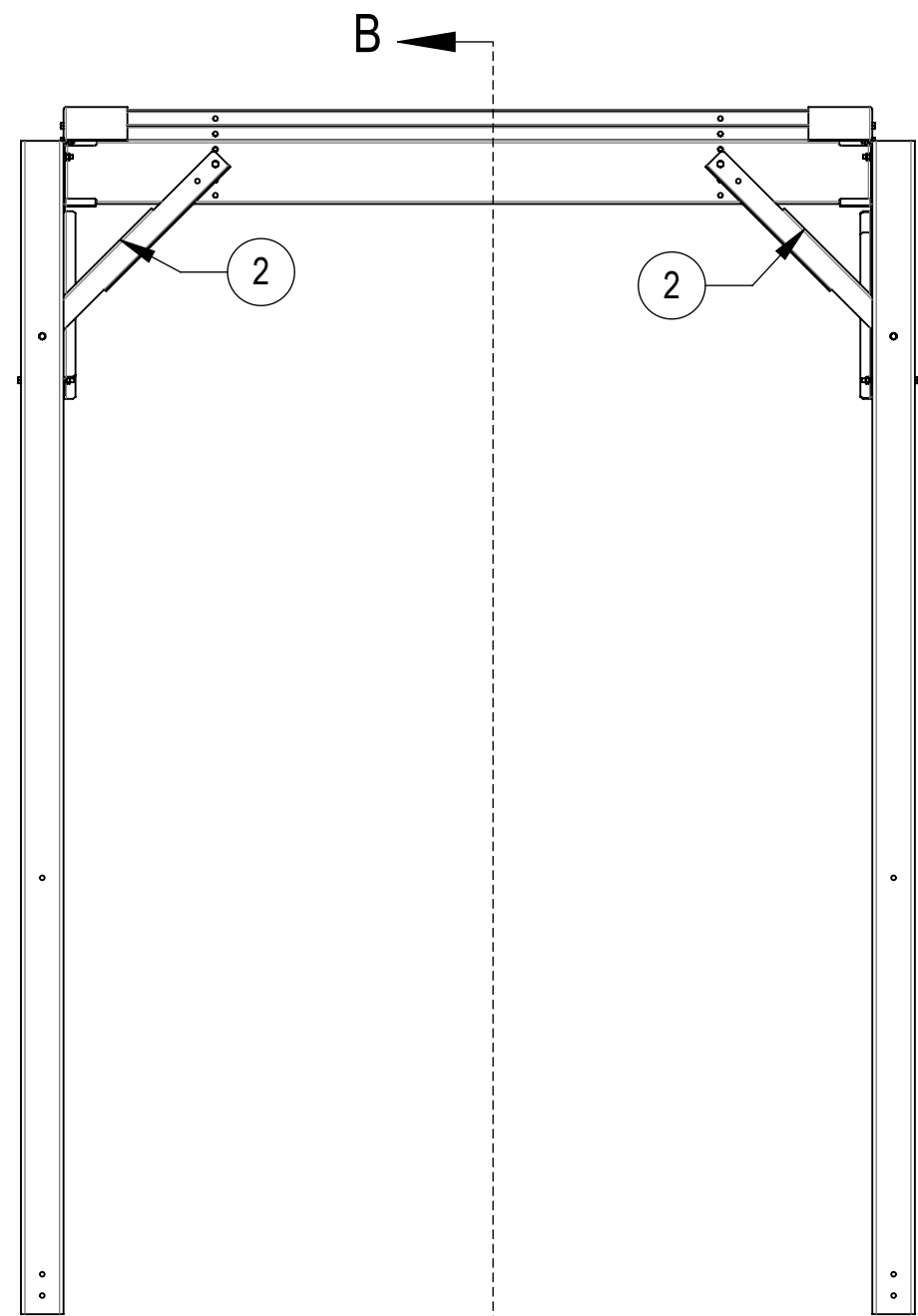
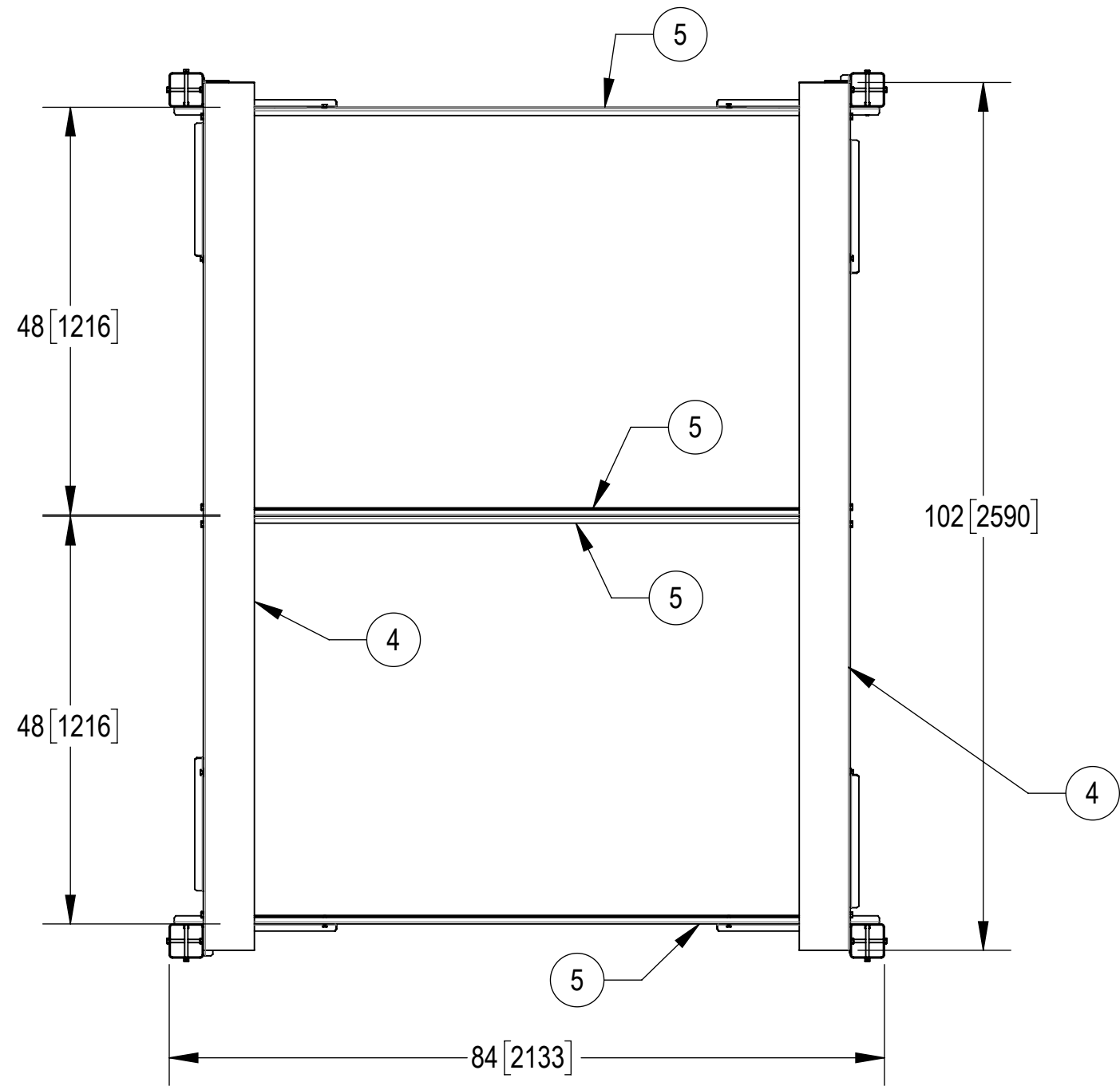

				
TITLE				
8'X8' HD 18GA, PROT PLAT CAN				
SIZE	SCALE	DOCUMENT NO.		
C	1:18	MTC4037CRHD		
		DRAWING		SHEET
		VERSION	STATUS	REVISION
		01	RE	B
				2 OF 7

Confidential

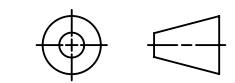

4

3

2

1

D

D

C

C

B

B

A

A

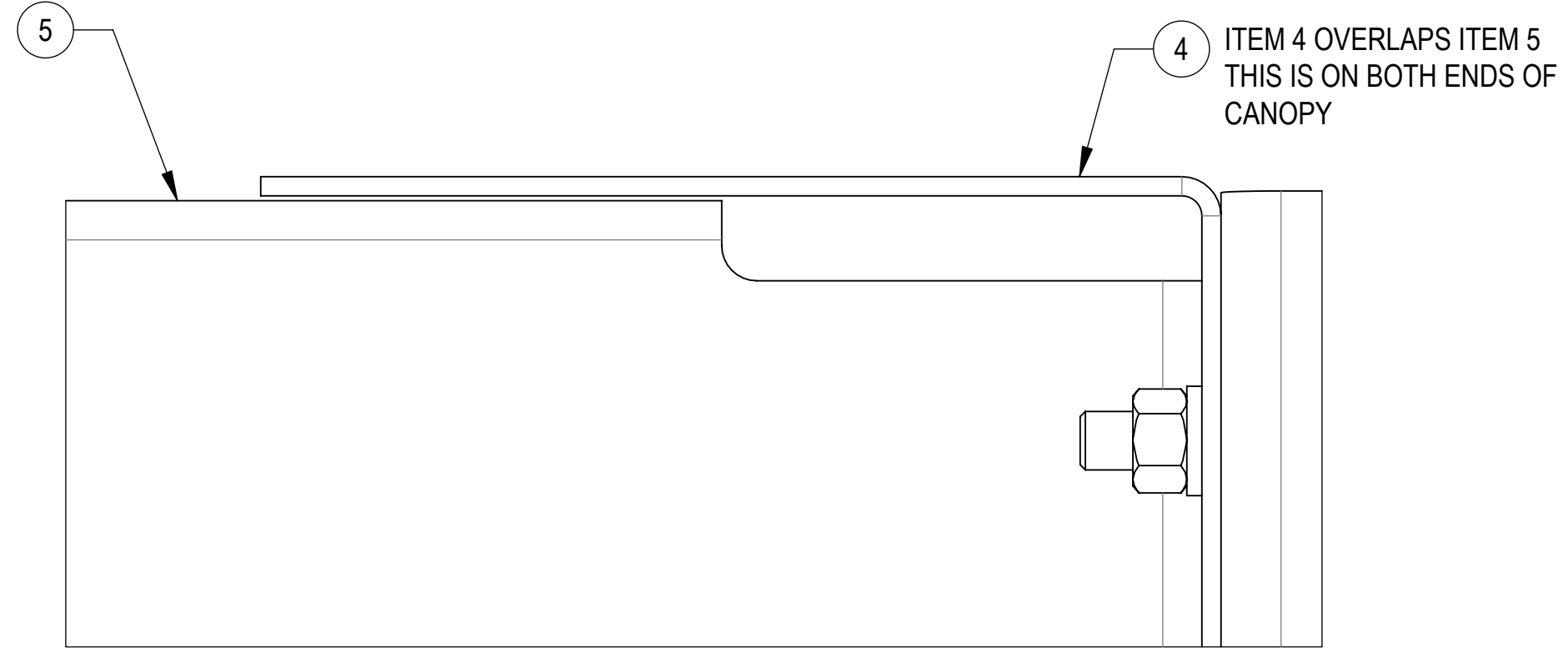
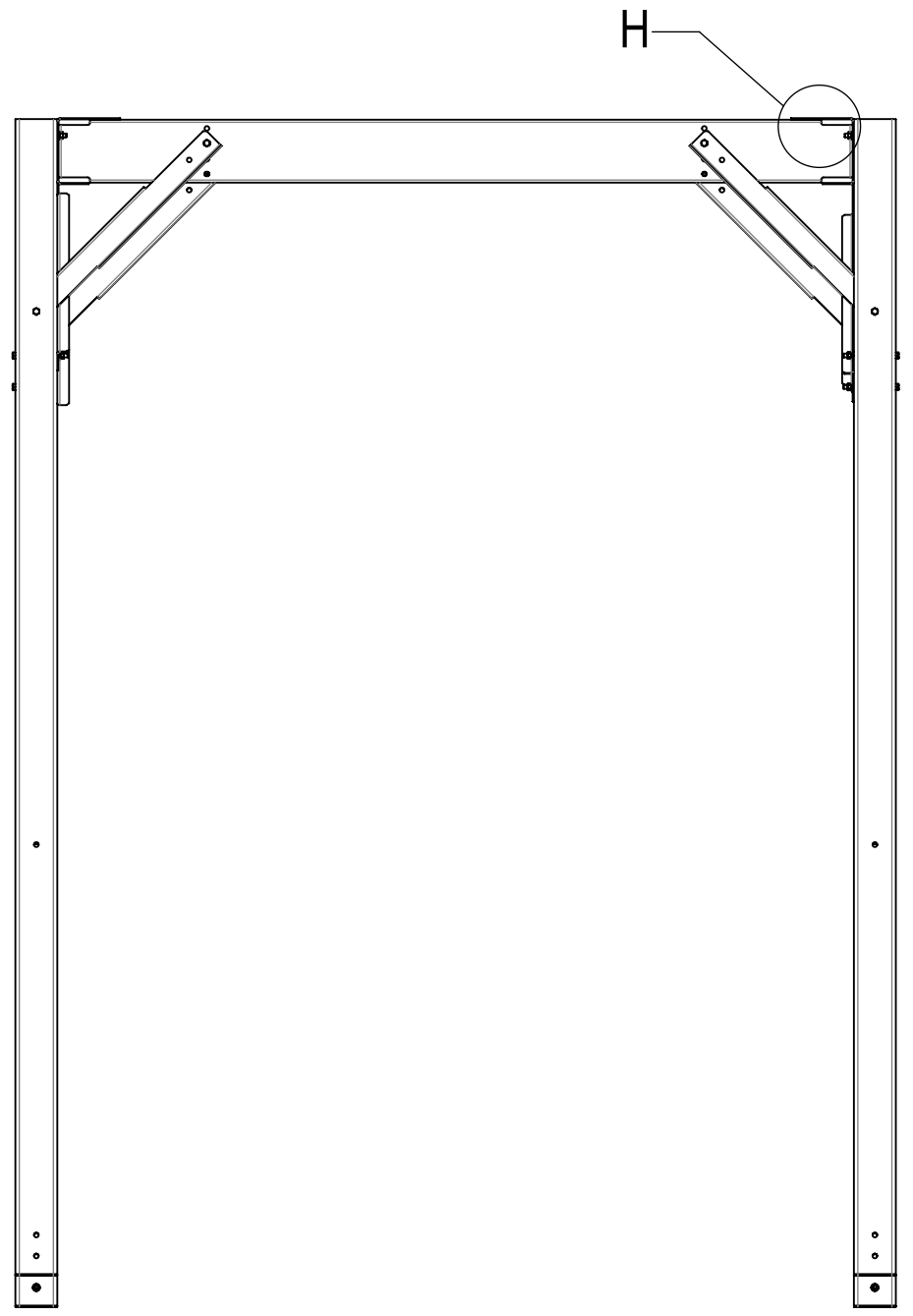

DETAIL H
SCALE 1 : 1



TITLE
8'X8' HD 18GA, PROT PLAT CAN

SIZE C	SCALE 1:18	DOCUMENT NO. MTC4037CRHD
------------------	----------------------	------------------------------------

	DRAWING			SHEET 3 OF 7
	VERSION 01	STATUS RE	REVISION B	

Confidential

4

3

2

1



THIS DESIGN SHOWS THE CANOPY TAPERS DOWN TOWARD THE BACK AWAY FROM THE STEPS.

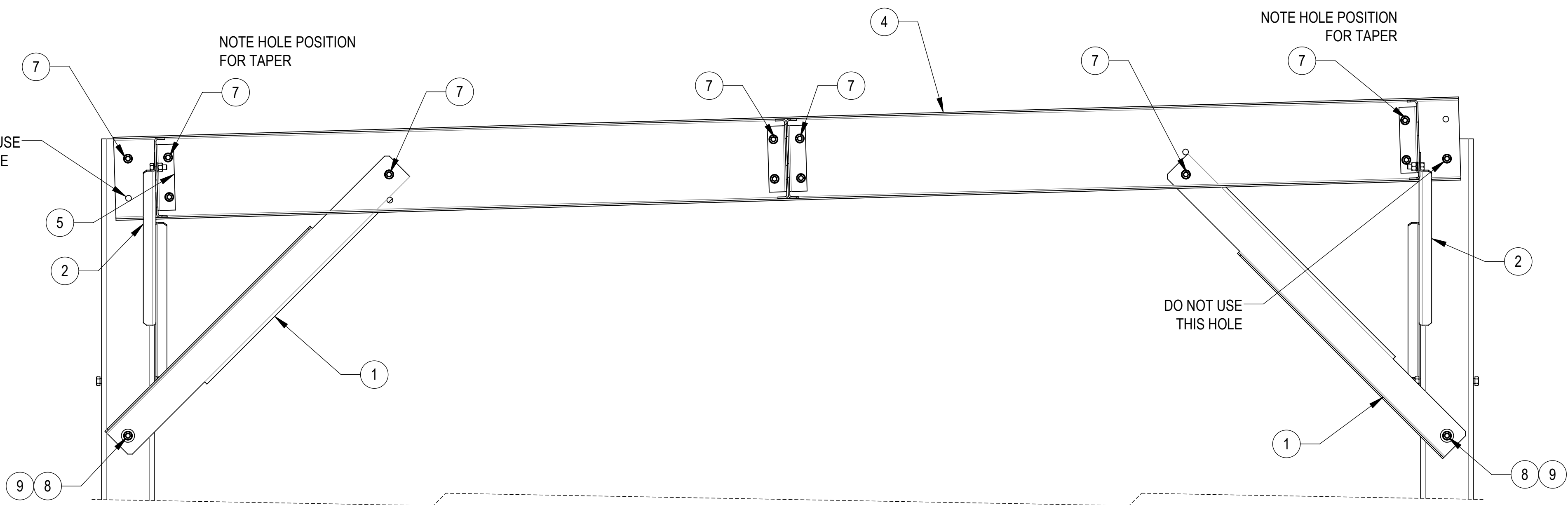



SECTION B-B

BACK LEG

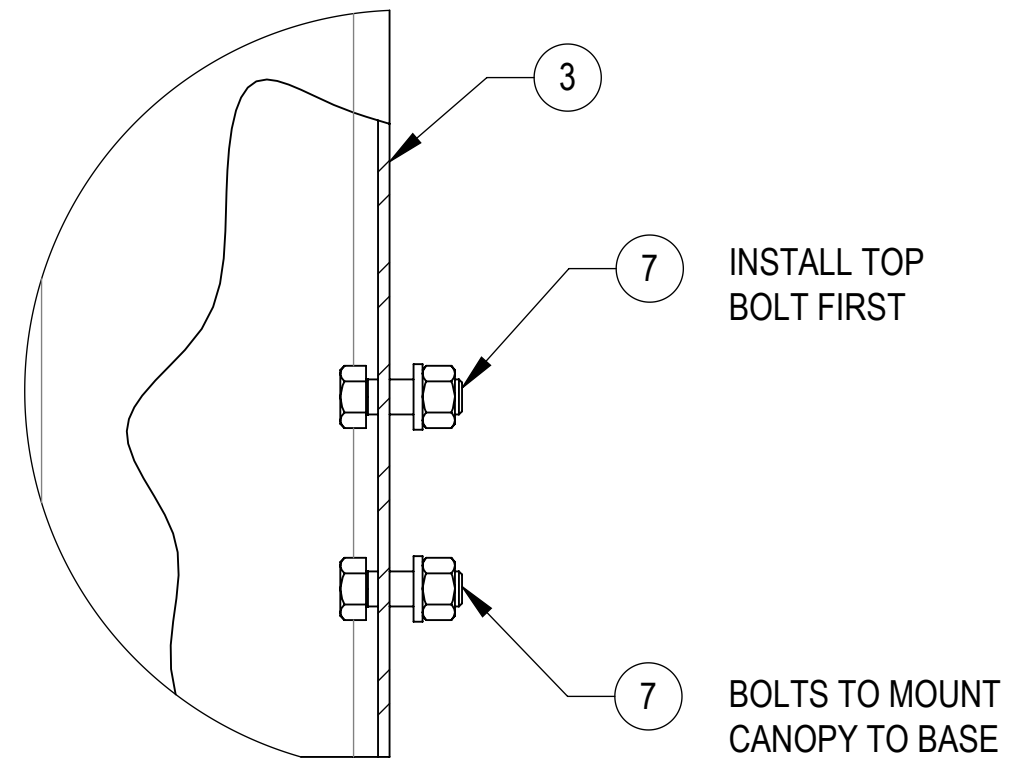
FRONT LEG

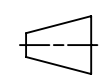

DETAIL G
SCALE 1 : 2

 ANDREW an Amphenol company				
TITLE 8'X8' HD 18GA, PROT PLAT CAN				
SIZE C	SCALE 1:6	DOCUMENT NO. MTC4037CRHD		
 		DRAWING		SHEET 4 OF 7
		VERSION 01	STATUS RE	

Confidential

4

3

2

1

THROUGH BOLT FOR
ATTACHING CHANNELS TO POST

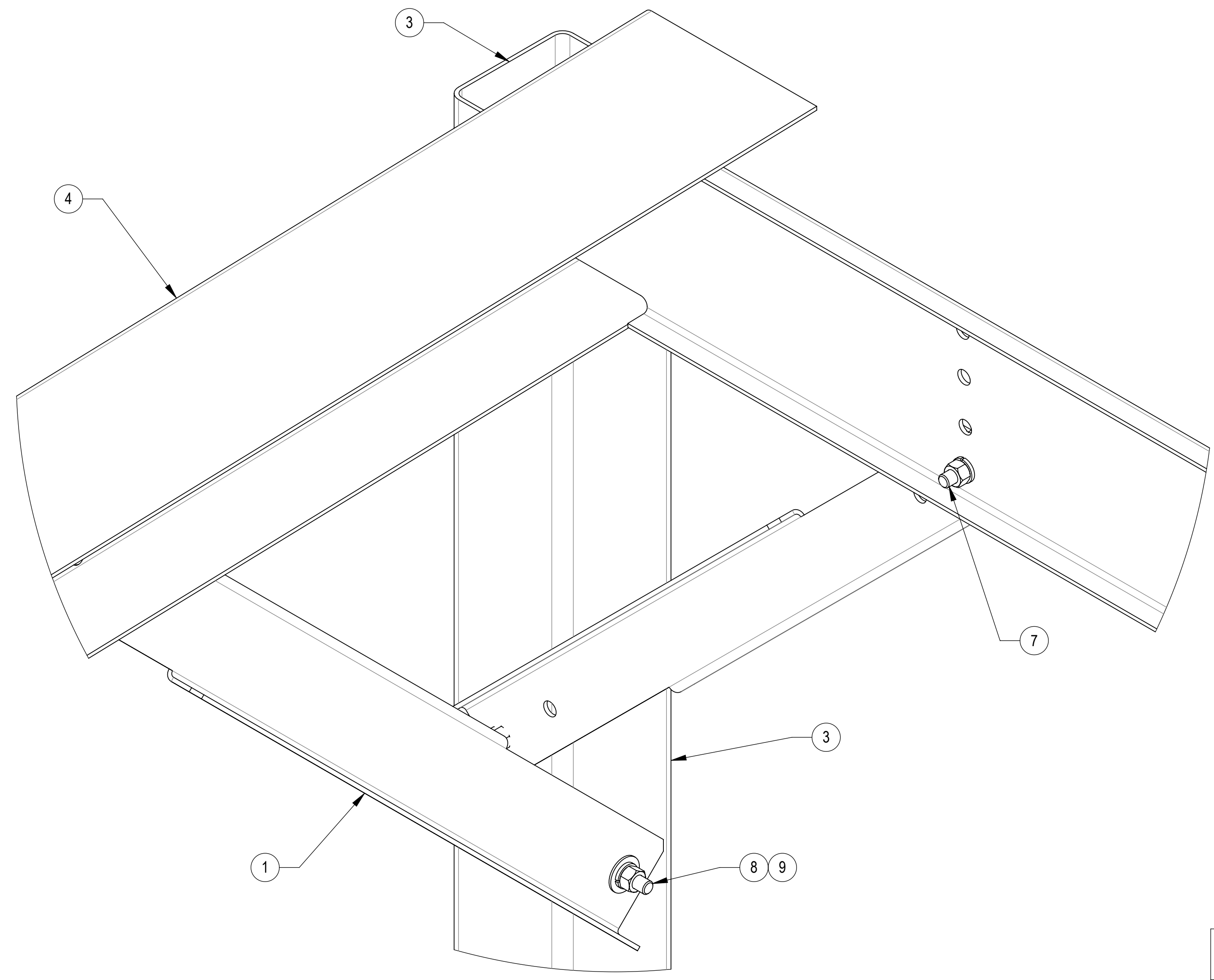

DETAIL A
SCALE 1 : 2



TITLE		8'X8' HD 18GA, PROT PLAT CAN		
SIZE	SCALE	DOCUMENT NO.		
C	1:8	MTC4037CRHD		
	DRAWING			SHEET
	VERSION	STATUS	REVISION	
		01	RE	B

Confidential

4

3

2

1

4

3

2

1

D

D

C

C

B

B

A

A

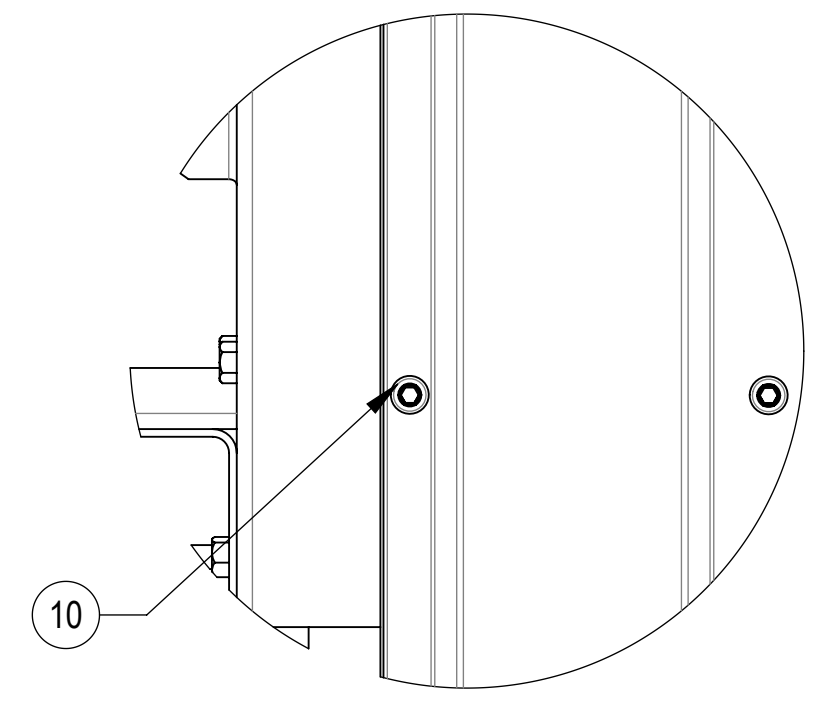
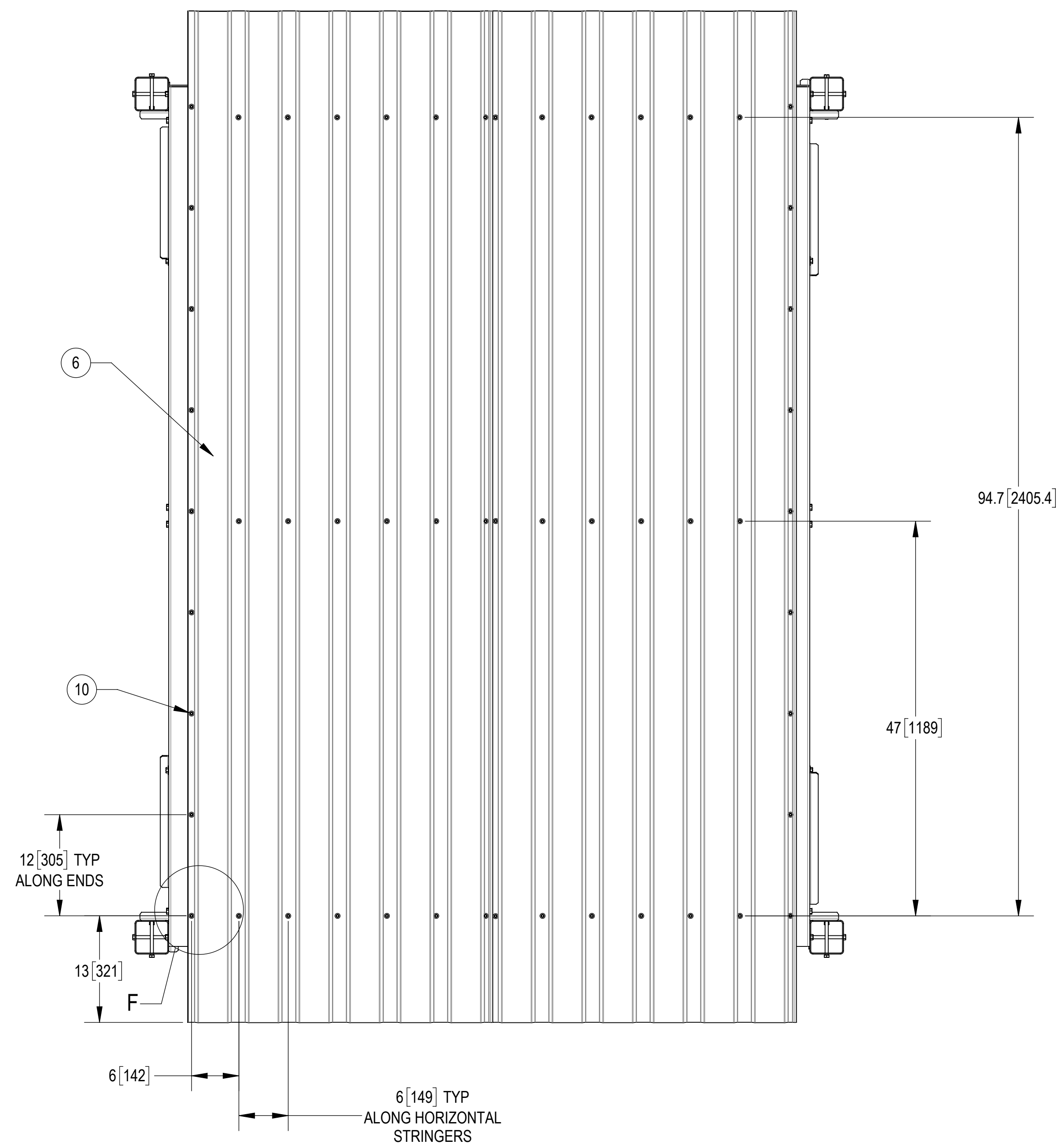

DETAIL F
SCALE 1 : 3



TITLE				
8'X8' HD 18GA, PROT PLAT CAN				
SIZE	SCALE	DOCUMENT NO.		
C	1:10	MTC4037CRHD		
	DRAWING			SHEET
	VERSION	STATUS	REVISION	
		01	RE	B

Confidential

4

3

2

1



4

3

2

1

D

D

C

C

B

B

A

A

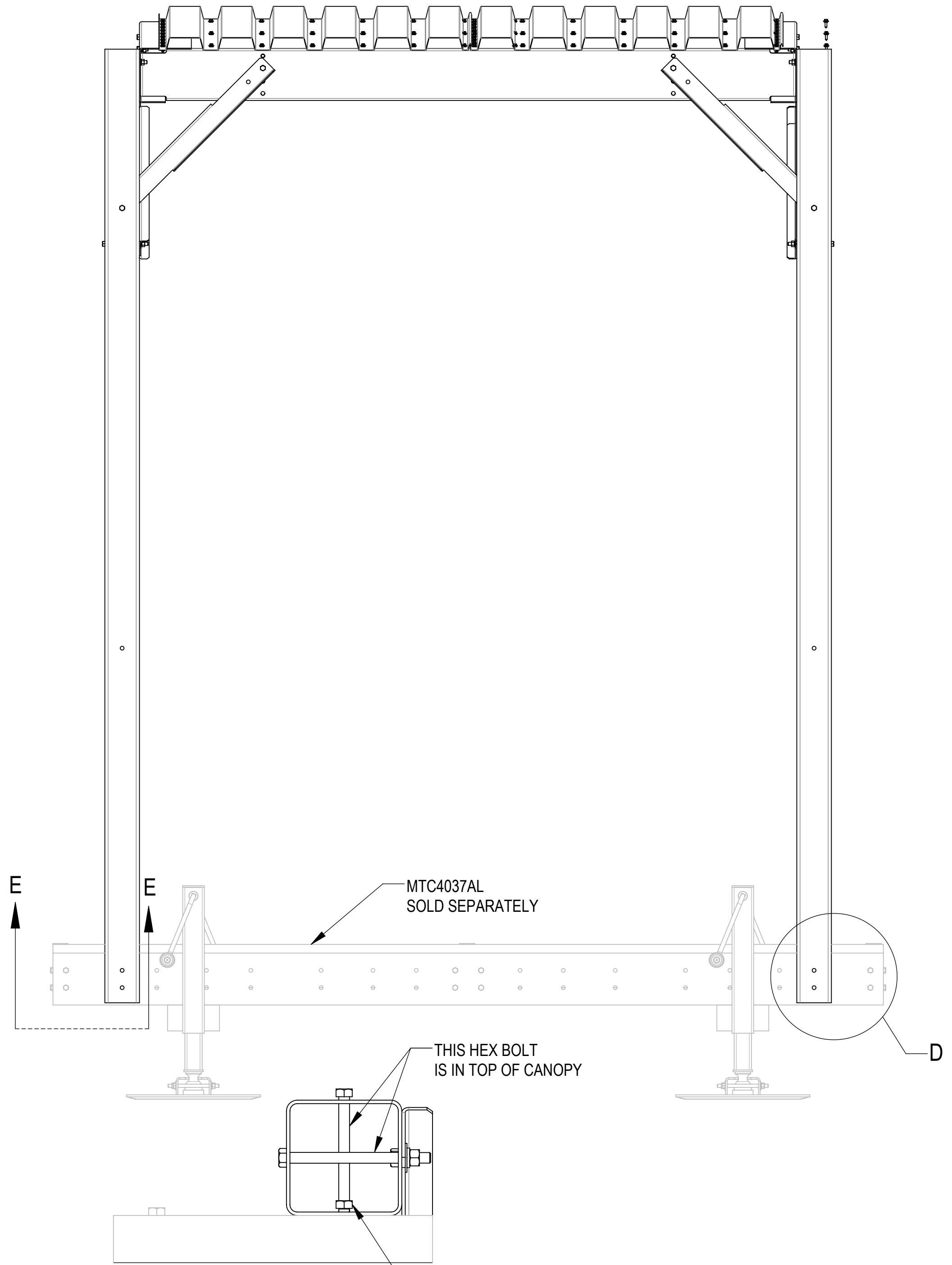

SECTION E-E
SCALE 1 : 3

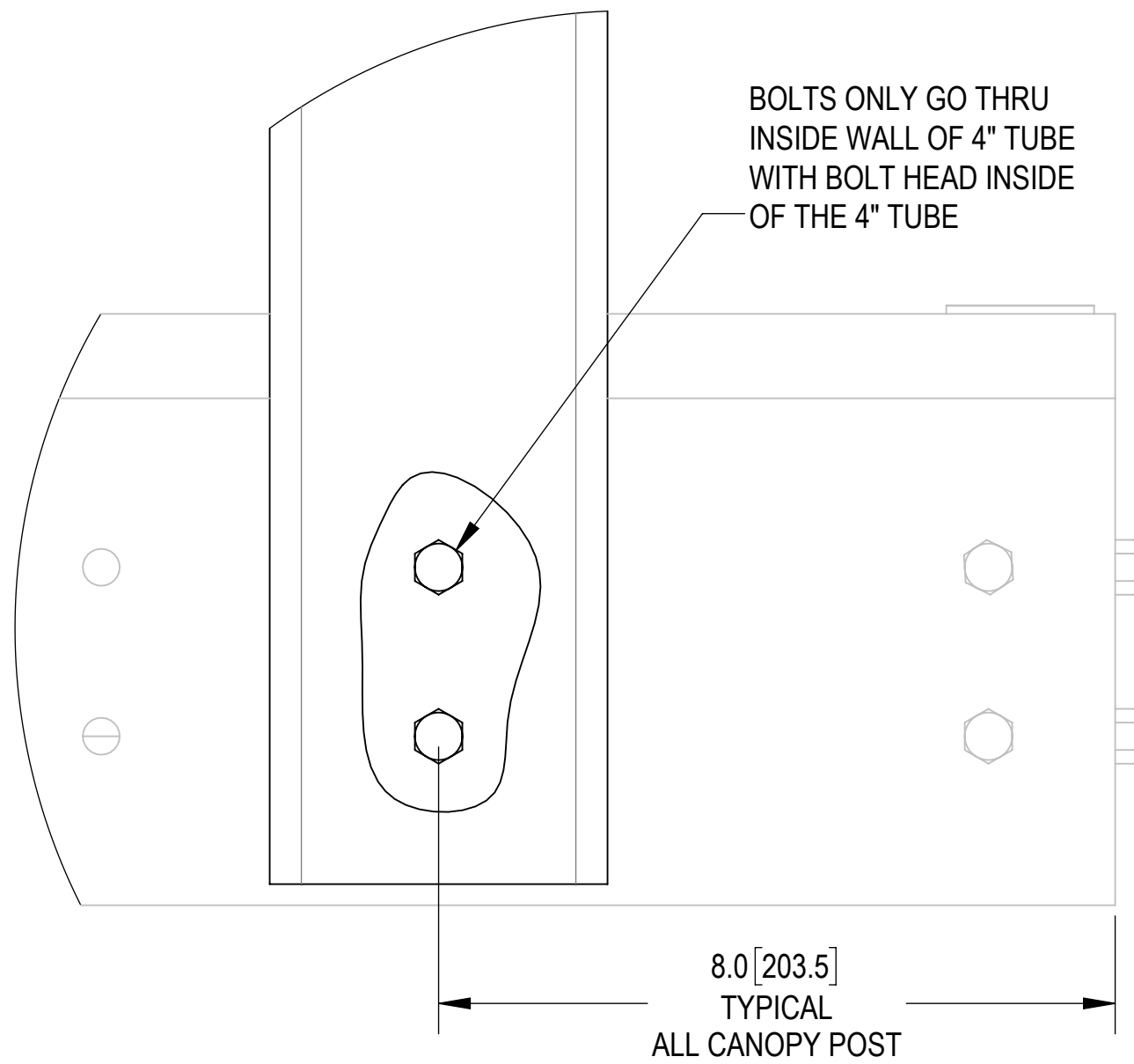

DETAIL D
SCALE 1 : 2



TITLE				
8'X8' HD 18GA, PROT PLAT CAN				
SIZE	SCALE	DOCUMENT NO.		
C	1:10	MTC4037CRHD		
		DRAWING		
		VERSION	STATUS	REVISION
		01	RE	B
				SHEET
				7 OF 7

Confidential

4

3

2

1