

- 1.0 GENERAL NOTES  
 1.1 ALL METRIC DIMENSIONS ARE IN BRACKETS [X.X]  
 1.2 FEATURES CRITICAL TO QUALITY ARE INDICATED IN ROUNDED BOX (X.X)  
 1.3 3D DIGITAL FILES ARE FOR REFERENCE. IN CASE OF CONFLICT FOLLOW PDF DRAWING
- 2.0 DESIGN NOTES
- 3.0 MANUFACTURING/SPECIAL REQUIREMENTS  
 3.1 THE FINISHED ITEM IS A SERIES ASSEMBLY. A -XX FINISH SUFFIX REPRESENTS SPECIFIC COLOR/FINISH. REFER TO METROCELL DOCUMENT MTM1004 FOR SPECIFIC REQUIREMENTS
- 4.0 TEST
- 5.0 PACKAGING  
 5.1 PACKAGING SHALL MEET ANDREW REQUIREMENTS PER DOCUMENT IS-PL-3005  
 5.2 WRAP THE UNIT IN PROTECTIVE FOAM WRAP BEFORE PACKAGING

REVISIONS			
REV.	DESCRIPTION	DATE	APPROVED
A	INITIAL RELEASE	ZL1057 29SEP25	WQ1001 50105036AMO

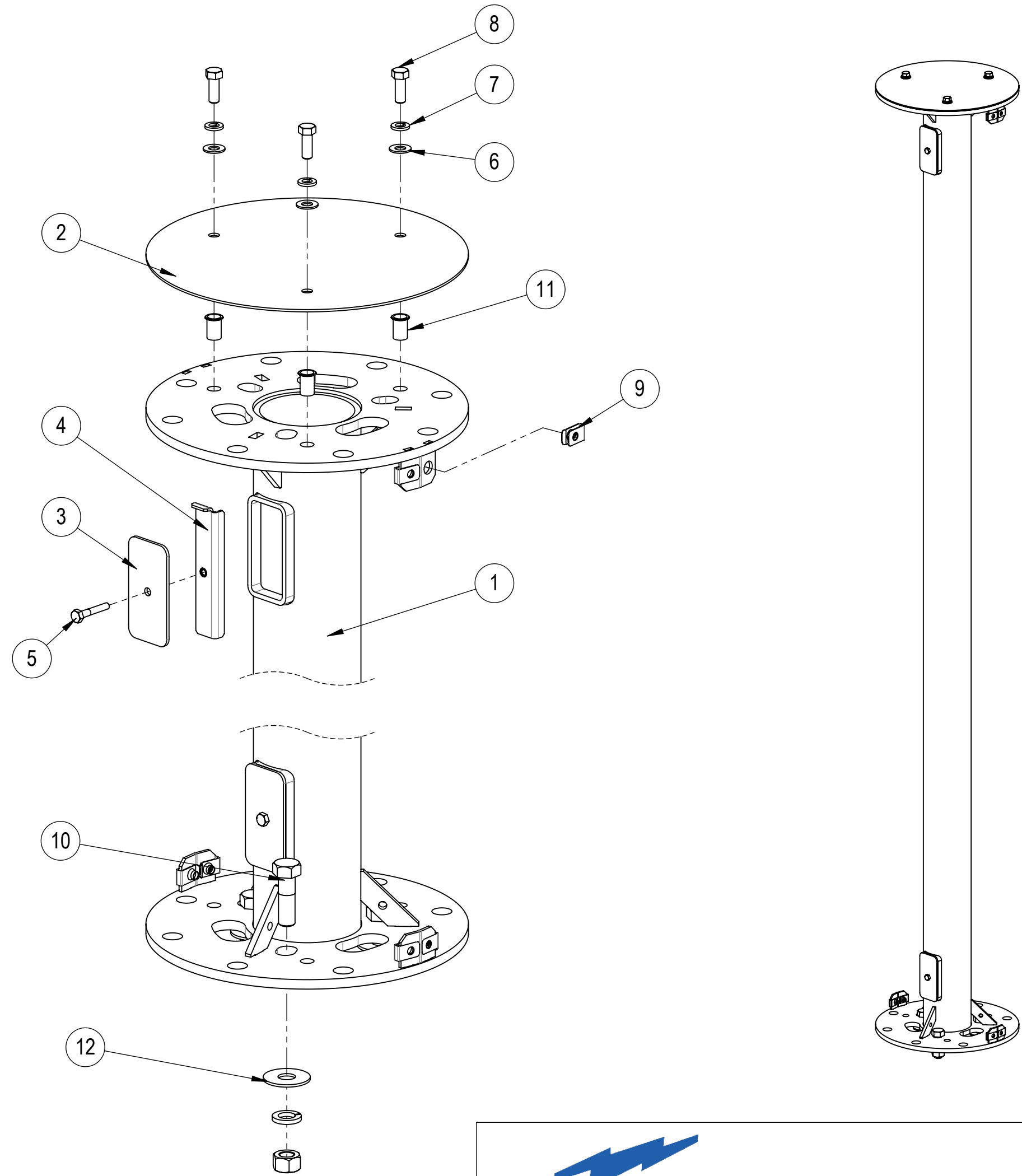
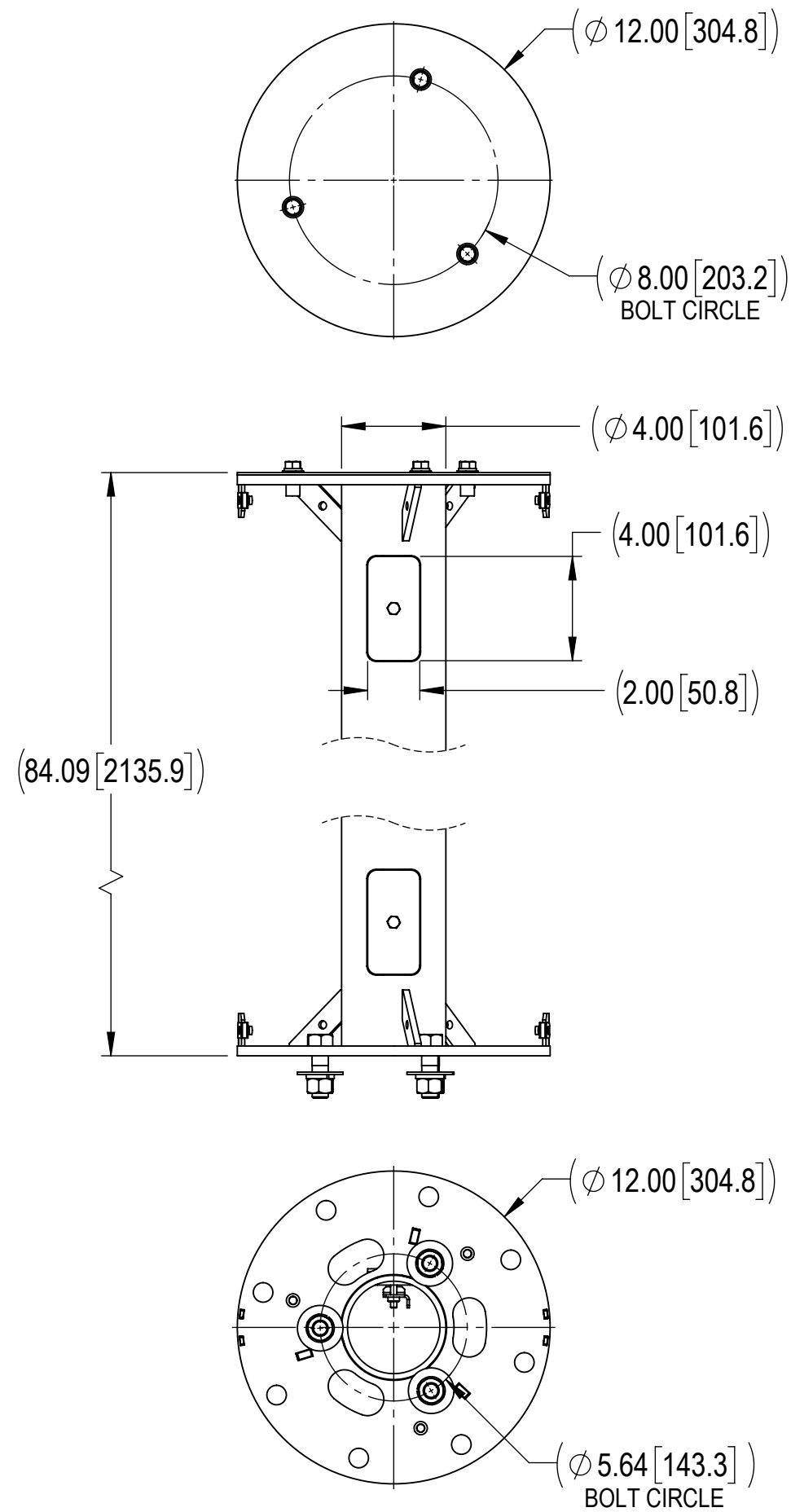

COMPONENT PART NUMBERS PROVIDED FOR ASSEMBLY PURPOSES;  
 INDIVIDUAL COMPONENTS MAY BE SHIPPED AS PARTS WITHIN AN INCLUDED KIT.

ITEM NO.	PART NUMBER	DESCRIPTION	QTY.	NOTE
1	MTM1225-1000-XX	MID CELL, SPOOL WELDMENT, 4" DIA, 7" TALL	1	
2	MTM1225-2000-XX	SPOOL TOP CAP, 12 DIA, ALUMINUM	1	
3	MTM1069-1300-XX	2 X 4 HANDHOLE COVER	2	
4	MTM1069-1200	2 X 4 HANDHOLE MOUNTING BKT	2	
5	MTC9406	.25" X 1.5" SS HEX BOLT	2	
6	SWF-03	3/8" SS FLAT WASHER	3	
7	SWL-03	3/8" SS LOCK WASHER	3	
8	SB-0310	BOLT, 3/8" X 1" SS (EA)	3	
9	460143456	CLIP NUT, M6, 316 SST	8	
10	GB-0520A	5/8" X 2" GALV BOLT KIT (A325)	3	
11	RN-03L844	3/8" STAINLESS STEEL RIV-NUT	3	
12	GWF-05	5/8" GALV FLAT WASHER, 1.70D	3	

DENSITY		lbs/in <sup>3</sup>
MASS	53.37	lbs
VOLUME	1942.21	in <sup>3</sup>
SURFACE AREA	4517.68	in <sup>2</sup>
HEIGHT	86.14[2187.9]	
LENGTH	12.00[304.8]	
WIDTH	12.00[304.8]	

Confidential

**ANDREW**® an Amphenol company

TOLERANCES: 1 PLACE .X[X] ± 0.2[6.3], 2 PLACE .XX[X] ± 0.12[3.0], 3 PLACE .XXX[X] ± 0.060[1.5], ANGLES ± 0.5°

SAP MATERIAL MASTER: 860685489-XX

FINISH: \_\_\_\_\_ MATERIAL: \_\_\_\_\_

NAME	DATE	TITLE
CE ZL1057	09/29/2025	MID CELL, SPOOL, 4" DIA, 7" TALL
RW ZL1057	11/02/2025	
AD WQ1001	11/05/2025	
RE DM1121	11/06/2025	

SCALE: 3:10 DOCUMENT NO.: 860685489-XX

SIZE	Auth Group	INSL	MODEL	DRAWING			SHEET
C			00	RE	A	00	RE A

VERSION: 00 STATUS: RE REVISION: A DRAWING: 00 STATUS: RE REVISION: A SHEET: 1 OF 1